

ELIET

MANUAL

Maestro City / Country



In this manual you will find information about the actual use and maintenance of the machine. **Read it carefully and keep it in a safe place.**



Please also keep your **purchasing invoice** or the proof of receipt together with this booklet.



Register your product online on **www.eliyet.eu**

© **ELIET**

Copyright 2018 ELIET. All rights reserved. All textual material, drawings, figures, diagrams, graphs, etc., included in this ELIET booklet are protected by copyright and also by other intellectual property rights. Nothing from this information may be copied for commercial goals or distributed and/or changed or reposted for other goals. Content has been included that specific places in this ELIET manual of which the copyright is the exclusive property of their respective owners.

1. Introduction



1.1 Carefully read this user manual

ELIET machines are designed for safe and reliable use if they are operated in accordance with the instructions given. Carefully read these operating instructions before using the machine. Failure to observe this may result in personal injury or damage to the equipment.

1.2 Identification data - ELIET MAESTRO City / Country

Note the identification data relating to your machine in the boxed areas.

Stock N°	<input type="text"/>
Serial N°	<input type="text"/>
Engine:	<input type="text"/>
Year of Manufacture:	<input type="text"/>

2. Warranty



2.1 Registration of your machine

In order to be able to make a warranty claim, you will need to register your machine online within one month after purchase: **www.elieta.eu / www.elieta.com**

European customers : ELIET EUROPE NV

Diesveldstraat 2

8553 Otegem - Belgium

T (+32)(0)56 77 70 88 - **F** (+32)(0)56 77 52 13

www.elieta.eu

Read the warranty conditions "read § 15. Warranty conditions" on page 56

US customers : ELIET USA Inc.

3361 Stafford street - USA

Pittsburgh, PA 15204 - USA

P 412 367 5185 - **F** 412 774 1970

www.elietausa.com

3. Welcome



Welcome to the family of ELIET customers.

We would like to thank you for the confidence that you have placed in ELIET and we are convinced that you have purchased the very best machine. The operating life of your ELIET machine depends to a great extent on how you care for your machine. This user manual and the engine manual provided will assist you in this respect. If you follow the instructions and suggestions in these manuals, your ELIET machine will operate for a very long time in optimal condition. Read this instruction manual carefully before operating this machine. This will prevent you from operating the device incorrectly.

For your own safety, take into account the safety instructions stated in the relevant chapter. Even if you are thoroughly familiar with operating such equipment, it is still advisable to read these pages carefully.

At ELIET all our machines and devices are subjected to a policy of continuous change and therefore, the specification of your machine may differ slightly in terms of shape, technology and accessories. The descriptions and technical data in this manual are accurate at the time of printing. Certain illustrations and descriptions may not be applicable to your specific machine, but instead relate to a different version of the machine. In turn, we trust that you will understand that the texts and illustrations in this manual cannot lead to any claims.

If you still have any questions after you have read this manual, we request you to contact your ELIET dealer.

ELIET AT YOUR SERVICE

European customers GMT +1: 8 - 12 u en van 13 - 17 u

Zwevegemstraat 136
B-8553 Otegem
België

Tel : (+32) (0)56 77 70 88
Fax : (+32) (0)56 77 52 13
Email: service@eliet.be

US customers: ELIET USA INC

3361 Stafford street
Pittsburgh, PA 15207
P 412 367 5185 - F 412 774 1970

4. Table of contents

1. Introduction	4
1.1 Carefully read this user manual	4
1.2 Identification data - ELIET MAESTRO City / Country.	4
2. Warranty	4
2.1 Registration of your machine.	4
3. Welcome	5
ELIET AT YOUR SERVICE	5
5. Operator safety warnings	8
5.1 For your information	8
5.2 Caution	8
5.3 Warning	8
6. Main parts	9
6.1. Machine survey	9
6.2 Engine	10
7. Safety regulations	12
7.1 Safety messages	12
7.2 Safety features.	15
7.3 General Safety Precautions	17
8. Dealer Preparation	20
9. Operating instructions	24
9.1 Preliminary checks	24
9.2 Filling up with Petrol.	25
9.3 Preparing the operating area	26
9.4 Starting the Petrol Engine.	26
9.5 Using the Machine.	28
9.5.1 Before Starting Work	28
9.5.2 During the work.	28
9.6 Emptying the collection bag	30
9.7 What To Do about Engine Stalling.	31
9.8 Cleaning the Machine.	33
10. Transporting the machine	34
11. Maintenance	36
11.1 General.	36
11.2 Maintenance schedule	37
11.2.1 Routine maintenance before each operation:	37
11.2.2 Maintenance after every 20 hours of operation:	37
11.3 Routine check prior to any operation	38
11.3.1 Visual inspection.	38
11.3.2 Checking the engine's oil level	38
11.3.3 Cleaning the air filter	39
11.3.4 Routine check of the blades	39
11.3.5 Grinding the blades.	41

11.3.6 Reversing and changing chipper blades	44
11.3.7 Changing the engine oil.	50
11.3.8 Checking and/or changing the spark plug	50
11.3.9 Changing the air filter.	51
11.3.10 General lubrication treatment	51
12. Winterizing the machine	53
13. Equipment Specifications	54
14. EC Declaration of Conformity	55
15. Warranty conditions.	56
What is warranty ?	56
Warranty conditions	56
16. Annexes	58
16.1 Hazard analysis	58
16.2 Opening and closing the chipping chamber	59
16.3 Removing and reinstalling the blade shaft	59
16.4 Dismantling the infeed hopper	61

5. Operator safety warnings



A number of symbols are used in this user manual to provide additional information and to highlight dangers.

5.1 For your information



For your information:

This symbol is used to draw your attention to specific information and/or actions, or to denote where you can find additional information relating to the subject.

5.2 Caution



Caution:

This notice identifies safe usage habits. This is done to prevent incorrect actions that can result in personal injury or damage to the machine.

5.3 Warning



Warning:

This notice is used to denote danger to consider in these specific circumstances. Thus remain alert, in order to ensure your own safety.

6. Main parts

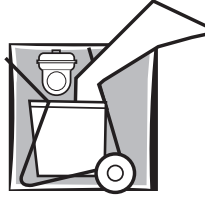

To fully grasp the contents of this operator's manual, you need to be thoroughly familiar with the terminology used for the descriptions. In this chapter you can find a set of parts identified by name.

It's a good idea to take time to study the machine beforehand for an improved understanding of the descriptions given in this user's manual.

6.1. Machine survey

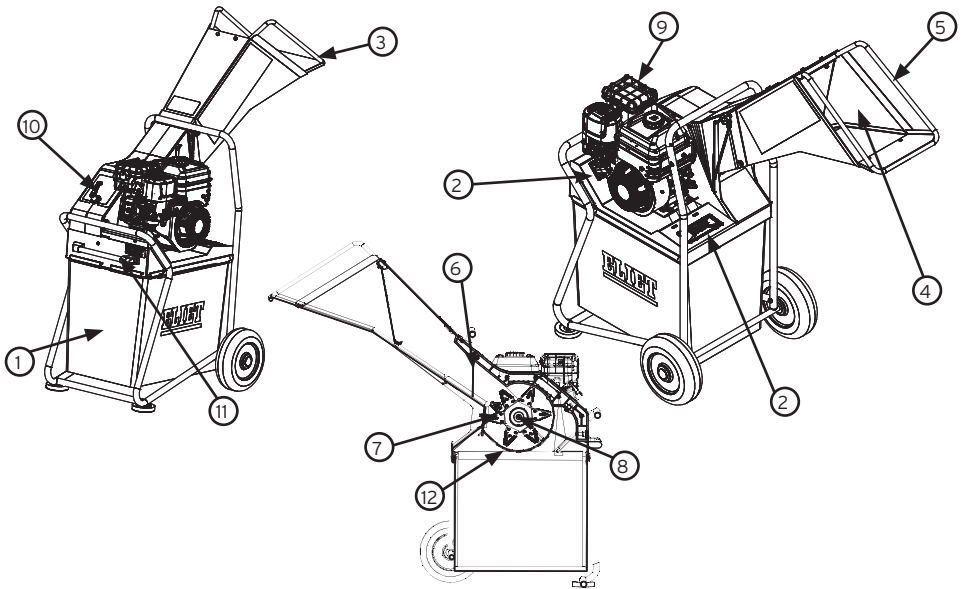

- | | |
|----------------------------|---|
| 1. Collection bag (Output) | 7. Blade axle |
| 2. Looking window | 8. Bearing |
| 3. Handle for transporting | 9. Exhaust |
| 4. Loading hopper (Input) | 10. Turning lever Fastener Sieve screen |
| 5. Anti-kick back guard | 11. Handle collection bag |
| 6. Anti-kick back rubber | 12. Sieve screen |

6.2 Engine

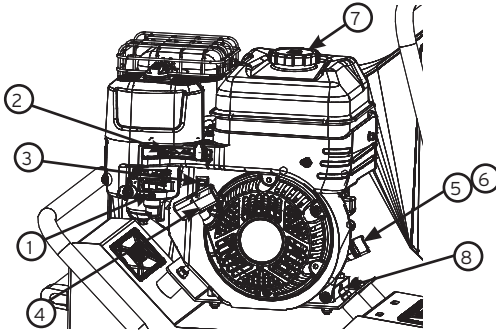

Briggs & Stratton
XR 750 / XR 950

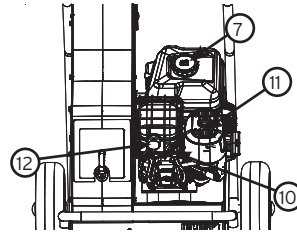

1. Choke
2. Engine speed control
3. On/Off switch
4. Ripcord starter
5. Dipstick
6. Oil filler cap

7. Petrol filler cap
8. Oil drain plug
9. Fuel shut-off valve
10. Spark plug
11. Air cleaner
12. Muffler

Honda GX160

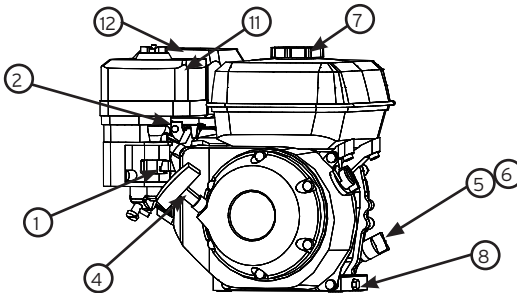

**For your information:**

Reference in this manual to right or left hand side, back or front of the unit is observed from the machine operator facing the branch feed.

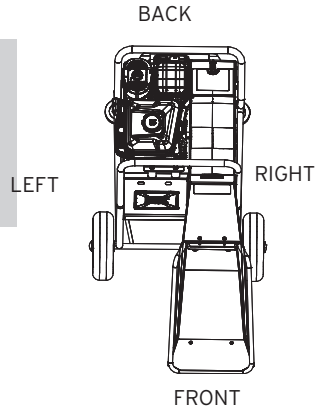
**For your information:**

Your ELIET Dealer is at your service, ready to provide you with maintenance or advice to keep your ELIET machine operating at peak efficiency at any one time. Parts and lubricants can be obtained from your ELIET Dealer. These service parts are manufactured to the same stringent accuracy and degree of craftsmanship as the original equipment.

**Warning:**

For your safety, use only genuine ELIET parts on ELIET machines.

7. Safety regulations



7.1 Safety messages



Decal location : On the left side of the loading hopper. This decal is used to denote all the safety precautions using icons.

1. Read this owner's manual carefully in its entirety before attempting to operate this unit.
2. Always wear the appropriate protective garment when operating the machine (protective gloves, safety goggles, hearing protectors).

(Stock number: BQ 501 020 310)



These icons are pictured on the left side of the loading hopper. They warn for the danger of cutting injuries to hands and to the danger of kickback material. Do not put your hands passed the safety protection screen.

(Stock number: BQ 501 020 310)

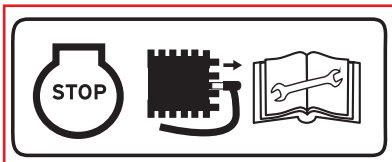

These icons are pictured on the left side of the loading hopper.

When performing a maintenance to the machine, always turn off the engine. Put the switch on the engine to the OFF-position, in order to provide accidentally turning on the engine. Do not allow third parties near the machine while performing a maintenance. Always read the user manual before performing a maintenance to the machine or to the engine.

(Stock number: BQ 501 020 310)



This sticker is put on the safety screen inside the feed hopper. This sticker warns the user of the danger of hand injuries and of flying debris. These are two risks - inherent in chipping branchy material - which are catered for by the safety screen. This sticker reminds the user how to operate the shredder in a safe way. No attempt should be made to put your hands past the safety screen!
(Stock number: BQ 505 010 140)



This icon is pictured on the left side of the loading hopper. This sticker reminds the user to keep bystanders out of the area during machine operation.
(Stock number: BQ 501 020 310)

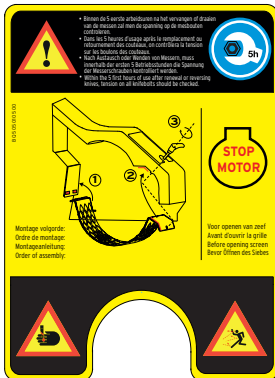

This decal is located on the protection chamber of the knife axle. It reminds the user to check the tension on the blade bolts regularly. The decal describes the manner of disassembly and assembly of the screen, and warns the user to switch off the engine before opening the screen.
The decal also warns the user for the danger of cut wounds to hands, and for the danger of debris projection when opening the sieve.
(Stock number: BQ 505 010 500)

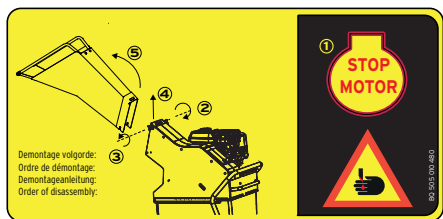

This sticker is located on the top side of the loading hopper. The way and manner of disassembly of the loading hopper is shown on this sticker. The loading hopper can be disassembled for transportation and for compact storing of the machine. The decal reminds the user to shut down the engine before disassembling the loading hopper. If disassembled there is an increased risk of contact with the blades and risk of cut wounds. (Stock number: BQ 505 010 480)

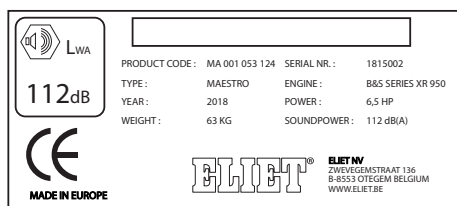

This sticker is used to indicate all the machine identification data.

- Year of manufacture
- Model
- Type number
- Serial number
- Power
- Weight
- Guaranteed A-weighted sound power level

Moreover, the sticker indicates all manufacturers' information.

The CE mark on the label testifies the conformity to European Standards.

7.2 Safety features

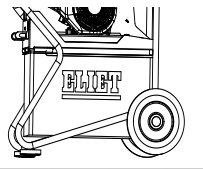

The collection bag:

The collection bag is located on the underside of the machine. Remove the collection bag and the motor automatically shuts off. In so doing, the collection bag prevents you from inserting your hands into the rotating shred knives. In order to prevent the collection bag from opening when shredding, it is locked in its position with a powerful magnet.



Warning:

The knives may continue to rotate for a few seconds after the engine is shut off. Wait for 15 sec. before starting an intervention. Be careful not to cut your hands.

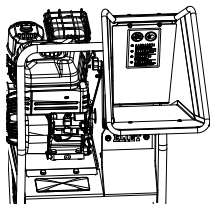

Safety screen:

The steel sheet located within the infeed opening, is specially designed to protect the operating personnel against flying wood chips. Any attempt by the operator to insert his hands beyond this steel sheet is strictly forbidden.

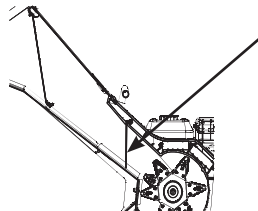

Anti-projection rubber:

At the entrance of the shredding chamber there is a synthetic flap that limits the fly-back of chips out of the chipping chamber. It is also a last shielding against involuntary contact with the blades.

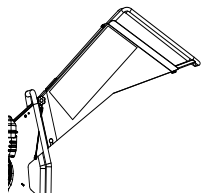

Loading hopper:

The shape of the loading hopper ensures the safety of the operator and is a protection against his personal carelessness. If the operator ignores the warning, and inserts his hands beyond the debris deflector shield, then this hopper impedes access to the shredding chamber in as much as injury caused by the shredding knives through the infeed opening is virtually impossible.

Safety switch on the loading hopper:

To be able to store the machine compact, the loading hopper is removable. To prevent accidents from happening when the machine is working, a safety switch was installed. It shuts down the engine automatically as soon as the screws of the hopper are loosened. This also prevents the machine from being used without the loading hopper.

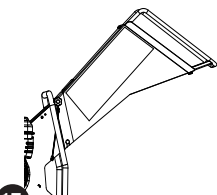

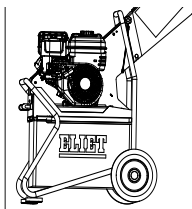

Rugged construction:

The robust construction not only adds to the long operating life of the machine but also provides extra user safety whenever there is an unforeseen emergency.

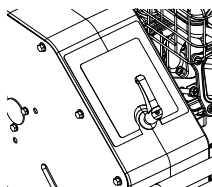

Sound absorption:

The double-walled acoustic housing accommodating the knife drum gives excellent noise reduction whilst shredding, therefore, minimising noise nuisance for both the operator and the surroundings.

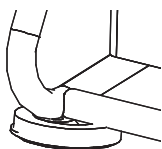

Rubber support feet:

The rubber support feet absorb vibrations of the machine, and they also have a restricting function. A machine on a slope will not slide down.

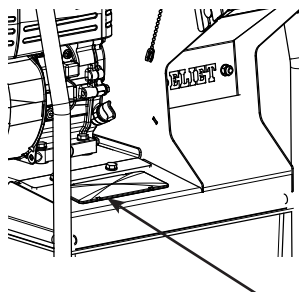

Looking window:

In the top plate of the chassis a sight glass is provided so that the user can control at all times in a safe way the volume in the collection bag.

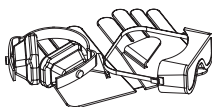

Safety wear:

For your safety, we strongly recommend to use the safety kit supplied as standard. It contains your Personal Protective Equipment (PPE) : that is, safety goggles, ear defenders and protective gloves.

7.3 General Safety Precautions

- The owner must retain the manual during the complete service life of the machine. It serves as a reference for the user, therefore, enabling the machine to be used and maintained in accordance with the correct instructions.
- This machine is designed solely for shredding branchy material, pruning, leaves and all kinds of organic garden debris. Any use other than the designated operation is at the risk and responsibility of the operator.
- According to the manufacturer,, this model will take branches up to 40 mm - 1 37/64 " (city) / 45 mm - 1 49/64 " (country) diameter. Branch feed is not mechanically limited to this stated capacity ; it follows that any attempt to introduce thicker branches must be avoided. For your own safety on no account should any attempt be made to introduce stems thicker than the stated capacity.
- Never attempt to shred branches that are frozen.



Warning:

Accepting branches with diameter up to 40 mm - 1 37/64 " (city) / 45 mm - 1 49/64 " (country) , this machine, however, is not designed for continuous shredding to the stated capacity. In the interest of your own safety, it is recommended that only 10% of the green waste exceeds this diameter.

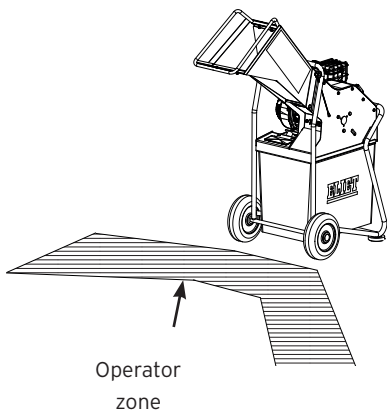

- This equipment must only be operated when stationary. Here, make sure the tyres and the frame are brought into contact with the ground.
- The operator's position when shredding is the surrounding area within arm reach located on the front of the infeed opening.
- Never use a step for feeding the machine with material.
- The equipment must under no circumstances be modified.
- Do not use the machine without loading hopper
- Observe all safety instructions when using the ELIET machine ! Carefully read the instructions on using the machine. All these instructions relate to your personal safety.



For your information:

Also, read the engine manual that is also supplied with the machine. This contains the necessary information on designated use and correct maintenance of the engine.

- Read the chapter that is meant for the Dealer ("read § 8. Dealer Preparation" on page 20) to find out whether the machine has been delivered as per instructions.
- On delivery of unit, first allow the Dealer or a professional to give you some instruction.
- Read and observe all safety messages posted on the machine in the form of decals.
- It is assumed that the operator of this machine is mature enough and has enough common sense to make decisions by himself.
- All persons using the machine are assumed to be familiar with the safety instructions. **The operator is fully liable for the use of the machine in regard to himself and to third parties.**
- Underage persons must not operate the machine. However, this does not apply to youths above the age of 16 years, who are learning to operate the machine under the supervision of an experienced operator. Children and animals must be kept well away from the machine.
- ELIET recommend that the machine should not be lent to others. However, if this is done, only lend it to persons who are familiar with the machine. Always ensure that the user is aware of the potential hazards, and ensure that he reads the manual before using the machine.
- This machine must only be operated by persons who are in a good physical condition. If you become tired during the work, take a rest in due time. Persons consuming alcohol or drugs must not operate this machine.
- You must wear proper apparel to operate this machine. That is, clothing covering the whole body, heavy protective gloves and closed nonslip footwear.
- Do not wear loose fitting clothing (a shawl, for instance, should be avoided by all means). Long hair should be contained using a cap or a headband, or worn in a ponytail.



Caution:

For the protection of the most sensitive senses, ELIET recommend hearing protectors and a safety goggle. These are included with the machine.

- Never work in conditions where the light intensity is less than 500 Lux.

- During work parties, do not allow bystanders to come within the risk zone that stretches up to 5m - 196,85" around the machine.

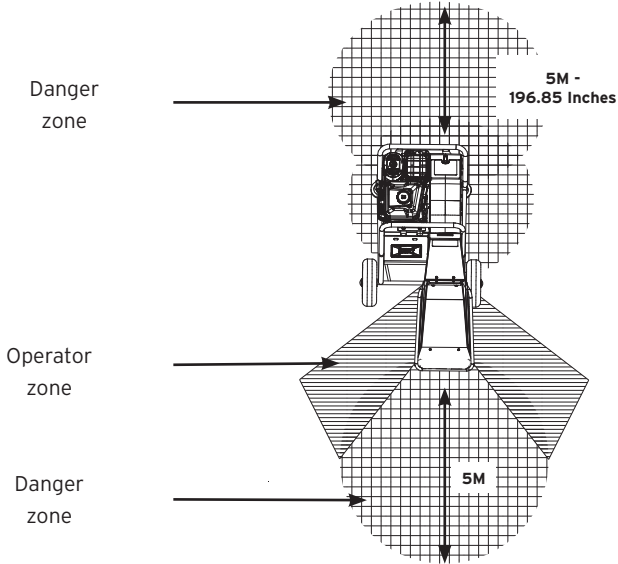

- When leaving the machine, the engine must be switched off.
- When parts must be renewed as a result of wear or failure, you must always request genuine ELIET service parts from your ELIET Dealer. This is important in the interests of your own safety.
- Use the machine in a manner respecting environmental regulations.
 - a) Avoid unnecessary machine running while not at work.
 - b) Avoid spilling petrol while refilling.
 - c) Service the engine regularly in order to achieve optimum combustion.

8. Dealer Preparation

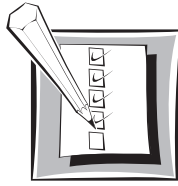

Warning:

As an ELIET Dealer you should familiarise your customers with the machine functions and also point out the possible dangers while using it. You are expected to carefully go over the maintenance points of the machine together with the new owner. You are supposed to repeat these instructions until the new owner has fully understood everything.



The manufacturer, ELIET, wish to re-emphasise that the Dealer must expressly point out to the customers that they must examine the bolts which retain the shredding knives for security of fixings after the first 5 (five) operating hours.

When the machine has been removed from its packaging, it is still not completely assembled. Your ELIET Dealer is expected to complete these preparation steps. Following are a few guidelines.

Following parts are found in the packaging on unpacking:

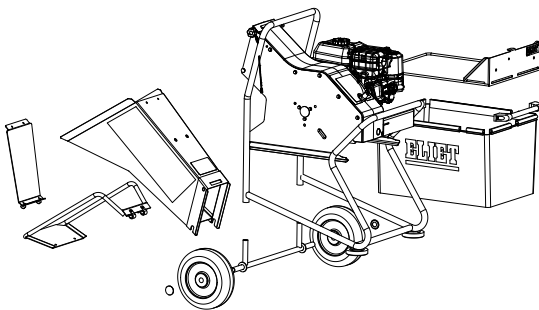

- Machine
- Feeding hopper
- Handle feeding hopper
- Two wheels
- Wheel support
- Collection bag
- Bag with fixing material
(Content: two Star-Lock caps)
- Set personal protection means
- Manual

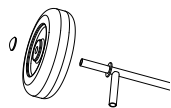

- First thing you have to do is fit the two tyres to the wheel holder. Secure them in position using the Starlock fasteners found in the plastic bag. Apply some grease (Sunoco Multipurpose LR-EP2, for instance) to the shafts beforehand.



- Next, slide the wheel holder into the machine chassis. Push the wheel holder in even increments until the frame tubes are a sliding fit over the vertical tube ends of the wheel holder. The wheel holder can be locked in this position by screwing an M8 bolt in the provided nut in the right gear tube.

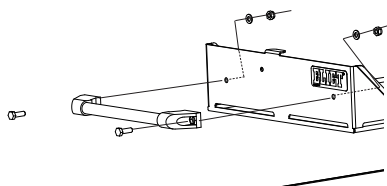

- Mount the handle of the collection bag. Slide the synthetic tube on each side of the tube holder. These are firmly bolted to the frame using the bolts and nuts that are included. (2xM6 - SLW10)

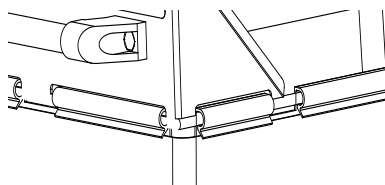

- Fix the collection bag to the frame that fits into the machine. In order to do so, the collection bag top face accommodates plastic retaining clips.

- To mount the handle to the funnel screw this in the upper side in the vibration dampers where the anti projection shield is mounted. To prevent the anti-projection plate, at a breaking down the rubbers would end up in the blade system, it is mounted between a nylon safety trip. (see drawing below)

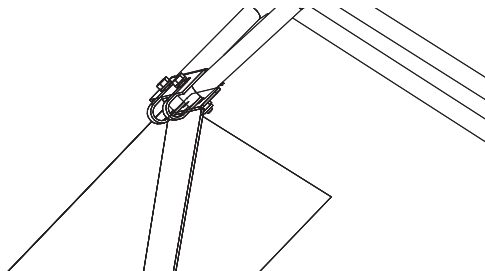

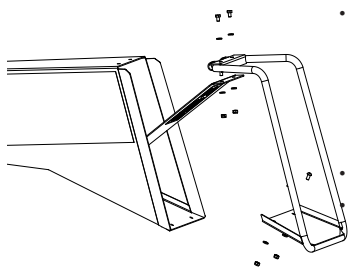

- Place the handle in the hopper opening so that mounting holes resemble the holes in the funnel. Fix the M6 bolts with a flat mounting disk in to the holes. Slid at the bottom the nylon security thread on the bolt and screw the rubber vibration damper on the bolt till the handle pushes against the funnel wall.

Then tighten the bolt tight (key size 10). If in this way both vibration dampers are mounted, slide the anti projection plate over the two excellent thread markers (make sure the nylon security strip is mounted between the vibration damper and the anti-projection plate). Screw the lock nuts (M6) with a flat washer stuck on the excellent thread markers of the vibration damper. Twist it tightly. (key size 10)

- Then we will mount the handle at the bottom. Place two round head bolts with a flat washer in the corresponding holes. Place the two bolts at the bottom on a flat washer and lock nut M6. Span the whole tight (hex wrench 4 and 10)

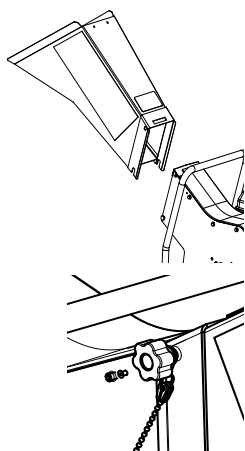

- After you have fitted the wheels to the chassis, proceed with installing the loading hopper. To do this, Slide the funnel over the throat of the machine and fix them into at the two notches on the bottom of the funnel over the two axles that pass over the bottom side of the throat. Make sure the long notch at the top of the feeding hopper hooks over the extending axle on the top side of the throat. This makes that the funnel stays in its position. Now we can screw tight the fixations screws on both sides of the funnel. Before screwing both screws put a little grease on the threaded fitting to simplify the fixing and loosening of the screws. Screw both screws firmly.

- The machine is packed without oil or petrol. The Dealer is expected to replenish with the correct oil and petrol as per instructions contained within this manual (or those within the engine manuals).
- With petrol engines, engine speed is factory set at 3,200 rpm.

**Caution:**

In the event of a petrol engine, the Dealer will pay particular attention to setting the correct engine speed. If the number of revolutions is too high, this will cause additional vibration with the resultant increase in wear rate. If the number of revolutions is too low, the machine will sacrifice power.

- The Dealer performs a test run on the machine and confirms that everything is functioning properly (such as the safety contact at the collection bag and on the loading hopper).
- Lastly, the Dealer makes sure the warranty card is filled in completely and signed. This, in order to avoid any warranty disputes. In this respect, read the warranty conditions.

9. Operating instructions

9.1 Preliminary checks



Caution:

Before commencing the work, it is recommended to get into the habit of checking the following points.

Checklist

1. Check the oil level of the machine. To this effect, remove the dipstick and make sure the oil level has not fallen to danger level (in necessary cases, “read § 11.3.2 Checking the engine’s oil level” on page 38).
2. Check ample petrol in tank beforehand. If not, add fuel (“read § 9.2 Filling up with Petrol” on page 25).
3. Make sure that the orifices of the air cleaner are not clogged (in necessary cases “read § 11.3.3 Cleaning the air filter” on page 39)
4. Satisfy yourself that the shredding knives are firmly in place and in good condition. If they need to be sharpened, this must be done first. Check the knives for cracks and nicks and replace immediately as needed (“read § 11.3.6 Reversing and changing chipper blades” on page 44).
5. Check whether the screen at the rear of the machine is secure, and has been fastened in the correct manner.
6. Verify that all of the machine’s safety items are operating correctly. (“read § 7.2 Safety features” on page 15).

Once these items have been checked and approved, you can prepare the area of operation (“read § 9.3 Preparing the operating area” on page 26) and move the machine to the work site.

9.2 Filling up with Petrol

Top up if the machine runs short of petrol. Use only clean, fresh gasoline. Use lead free fuel, gasoline with a minimum of 98 or 99 octane is to be preferred.



Warning:

Under certain conditions, gasoline is extremely flammable and extremely explosive. Fire and explosion caused by gasoline can result in serious burns or damage to property.

Thus, always take note of the following points.

- Never fill tank when engine is running.
- Topping up with gasoline may never occur while an engine is running. Always allow a few minutes for the engine to cool off before topping up with fuel.
- Use only fresh gasoline. In order to reduce air pollutant emissions, ELIET recommend lead-free gasoline. In order to extend storage life, mix additives with the fuel.
- Store fuel only in an approved container. Keep this container out of reach of children
- Never top up gasoline at a location where work will be performed later. Always keep the area of operation clear of all persons (10m minimum). This is to prevent any fire risk.
- Clean the fuel fill area first and then remove this cap. Never fill a tank to over 85% of the tank's capacity. Top up allowing approximately 10mm of tank space. Thus, do not fill the tank completely to the opening in the tank.
- Always use a funnel or spout to pour the petrol into the tank. Suitable funnels can be obtained from your ELIET Dealer.
- Refit the cap onto the tank. If petrol is spilt during the filling, the engine must be immediately cleaned.
- When gasoline has been spilled one will avoid this comes into contact with the viewing Windows. Gasoline can react with the plastic and affect the transparency or strength of the viewing Windows. Cracked or damaged viewing Windows have to be replaced. They can no longer guarantee safe use. (Item number: BR 920 220 040)
- Be careful not to spill petrol onto clothing. Should clothing become contaminated be careful to change clothes as soon as possible.
- It is unsafe and therefore expressly forbidden from filling the fuel tank in the vicinity of smokers or a naked flame.
- If fuel comes into contact with the eyes or is taken internally, get prompt medical attention.

9.3 Preparing the operating area

- Clear the area first where the machine is to be used. In addition, the paths along which the plant trimmings are removed, must be kept clear, thus releasing the operator from the worries of tripping up over them. The operator must also ensure that his safety is not compromised.
- On slopes, never operate the machine (no forward or lateral slope).
- Sort out as much as you can before you start the machine up. In this way, you are pretty sure that no foreign objects will enter the machine with the material to be shredded.
- With foreign objects are meant : any non-organic object or branchy material in excess of the stated capacity (such as metal, stone, plastic, pvc, cords,...). Some of these can cause serious damage to your machine or can be ejected, virtually as projectiles towards the user.
- Always position the machine so that the wind will blow the dust produced away from the engine.
- Also, check which way the wind is blowing to make sure the exhaust fumes will be blown away from the operator's position.

9.4 Starting the Petrol Engine



Caution:

Never start never the machine if dust or dirt lies on the engine between the cooling fins or is present on the engine. This prevents optimal cooling of the engine and more importantly can cause fire.

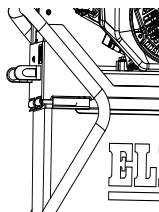

You will be unable to start the engine as long as the collection bag hasn't been pushed fully in the chassis and locked in position and the load hopper is mounted correctly.



For your information:

Also, read the engine manual. In the chapter entitled General you can find more information on the key engine functions. ("read § 6. Main parts" on page 9)

- Before starting the engine, check if there is adequate oil and fuel in the engine, if not, Read following paragraphs:
 - “read § 11.3.2 Checking the engine’s oil level” on page 38
 - “read § 9.2 Filling up with Petrol” on page 25
- It is essential to ensure that the loading hopper is free of any material.

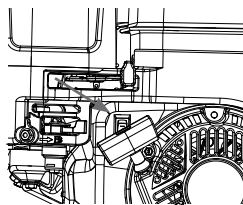

On-position

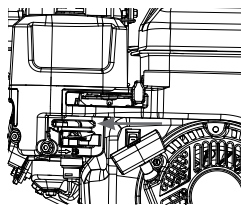

Choke

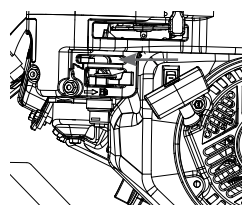

Throttle control

- Open the fuel shut-off valve by turning it in the ON position.
- Adjust the throttle control lever fully to the right to full speed.
- Move the throttle control lever to the CHOKE position, therefore, closing the choke

**Warning:**

Before starting up the machine, make sure to wear ear defenders.

- Start the engine by giving the recoil starter cord a strong pull. After the engine is running, quickly move the choke lever to RUN. This ensures that the engine does not receive too much petrol. If you forget to do this, then the engine will slow down and start to smoke profusely. Eventually, it will stop. Restart the engine without choke.
- When engine starting is problematic, it signifies that the spark plug is fouled. It follows that the spark plug needs cleaning or replacing (“read § 11.3.8 Checking and/or changing the spark plug” on page 50).

**Warning:**

The knife drum is driven directly by the engine. The knives remain engaged. This means that the machine becomes dangerous as soon as the engine starts running. Therefore the engine must be switched off immediately whenever you encounter a situation in which you lose control.

How to Quickly Turn off the Machine ?

- Through moving the engine throttle control lever to the left (see engine manual).
- Sliding the unlocked collection bag backward will also cause the engine to shut off.

9.5 Using the Machine

9.5.1 Before Starting Work

- Wear proper apparel, protective gloves and safety equipment as instructed in this manual ("read § 7.3 General Safety Precautions" on page 17).
- A good gardener is well organised and plans his work. This will enable him to have an overview of the work and to avoid accidents and incorrect actions with the machine..
- The wood is systematically stacked before commencing the work : thick branches, thin branches, leaves and damp material. Ensure that the material does not contain any foreign objects.
- The engine must only be started once arrived at the work site.
- Never run the machine in an enclosed area. If this is done, there is a danger of being poisoned by the fumes from the engine..
- Always adjust throttle to full speed (throttle control lever to the right).
- After the motor has started, allow it to warm up. This ensures that the motor attains its full power. The importance of this cannot be overstressed when shredding branchy material of maximum branch size.



Caution:

Once the engine is running, the shredding knives are rotating, therefore, irrevocably shredding anything that is introduced into the loading hopper.

9.5.2 During the work

- You must be careful when performing work. As long as you're operating the machine, focus your concentration completely on the work.
- When inserting the material, always hold it firmly. The rotational direction of the knife drum makes for steady material feed into the hopper. If you stop holding the wood firmly, it will automatically be pulled much too quickly into the machine which will inevitably lead to the machine stalling.
- You yourself will thus control the speed at which the wood is fed in (faster or slower). The speed at which the wood is fed in will vary according to branch size.
- You will listen attentively to the characteristics of the motor when feeding in the wood. If you notice a significant drop into engine speed, immediately pull the wood back out in order to allow the engine to speed up again.



Caution:

When feeding in wood, never insert your hands beyond the steel shield. By raising the safety screen, you are no longer protected against wood chips flying out of the machine.

- If the equipment is primarily used for shredding leaves or damp material using the standard sieve screen, the chances are good that orifices will clog. To alleviate this problem, The ELIET damp material shredding screen is a way around this. (**art. n° MA 001 052 001**) This shredding screen is available from your ELIET-dealer.
- If only a small volume of leaves is to be processed, they can be easily shredded using the standard screen. However, in this case, ELIET recommend that leaves and branches should be shredded alternately. In so doing, the wood chips prevent the screen orifices from clogging.
- As the waste chippings are collected in a collection bag, care must be taken in making sure at regular intervals that the chips will not block the discharge situated on the underside of the machine. Collection bag filling can be checked by looking through
- To promote collection bag consolidation, shake the bag regularly to distribute the waste chippings to fill the empty spaces in the collection bag.
- If you should notice that, despite all of the preparation, a foreign object still finds its way into the machine, the engine must be immediately shut off. The foreign object must be removed first and then the machine must be examined for damage. If damaged, have the damage repaired promptly.
- As a rule, the engine will shut off automatically on removing the collection bag. If not, possibly as the result of an electrical defect, immediately turn the engine off yourself and refrain from using it until repaired.

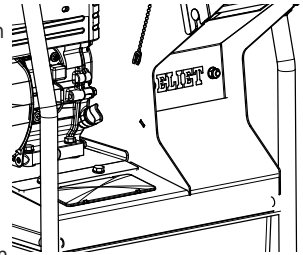

REMOVING THE COLLECTION BAG = MOTOR SHUT OFF

Normally, the engine shuts off if the feed hopper is loosened. If this is not the case, the machine operator will turn off the machine manually with the switch on the motor. The defect must be fixed immediately before proceeding the work.

REMOVING THE FEED HOPPER = MOTOR SHUT OFF

9.6 Emptying the collection bag

- The bag needs emptying when the waste chippings in the collection bag has reached the bottom of the discharge chute of the machine.
- In order to do so, always first make sure to shut off the engine (failure to do so will cause the engine to cut out automatically on collection bag removal).
- Failure to empty the bag in time will cause the shredding chamber to get clogged up and finally come to a stop. (“read § 9.7 What To Do about Engine Stalling” on page 31)



Caution:

A machine that does clog up is a sure source of overheating with the resultant increase in fire hazard.

- The collection bag has an approximative 60 L / 16 US gallon (City) / 80 L / 21 US gallon (Country) capacity.



Warning:

Once full, the collection bag can be pretty heavy. Which means - make sure to hold the collection bag close in towards your body as close as possible first and then lift using your leg muscles. (Lift keeping back straight and bend legs at the knees.) Know your own capability. The mere fact of lifting things beyond your personal capacity a mere few centimetres does serious damage. Seek assistance when lifting things that are too heavy for you.

- Either you can empty the contents of the collection bag in to a wheel barrow, or you can carry the full bag to the dumping area using the wheel barrow.
- What's more, the machine can be used for transporting the collection bag once full.
- When refitting the collecting bag you can secure it in position using locating pins.

9.7 What To Do about Engine Stalling

Engine stalling can be traced to overloading, overfeeding, discharge blockage or lack of fuel. The engine may well not restart immediately. To remedy the problem, do the following.

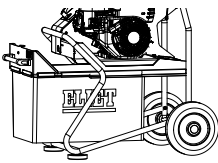

1. Check ample petrol in tank (*"read § 9.2 Filling up with Petrol" on page 25*).
2. Remove all branches from the feeding aperture.
3. Pull the starter rope briefly. This allows you to find out whether the knife drum is still jammed. As soon as you feel resistance, and cannot pull the starter rope any further, stop pulling. There is no point in pulling hard on the starter rope, as this can only cause it to break or overload the starter mechanism.
4. When the knife drum got jammed, the shredding chamber needs clearing. (*"read § 16.2 Opening and closing the chipping chamber" on page 59*)



Warning:

The knives are razor sharp, avoid cuts to the hands. Wear gloves !



Caution:

Be attentive when tilting the machine that no gasoline is leaking away.

5. Remove all wood chips and traces of wood that are in the shredding chamber. Chips that have accumulated on the top can be loosened by pulling the starter cord of the engine, To remove the chips that have accumulated on the top side, pull the starter cord of the engine slightly so the blade axle ejects the chips. Please note: avoid the presence of anyone else near the machine.

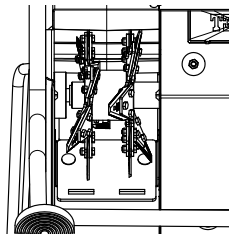

6. Carefully refit the shredding screen and check for correct refitting. (*"read § 16.2 Opening and closing the chipping chamber" on page 59*)
7. Refit the collection bag and restart the shredder (follow the start procedure as outlined in *"read § 9.4 Starting the Petrol Engine" on page 26*).

8. Perform the work more carefully in the future in order to avoid jamming of the machine.

If you notice a strange noise during shredding, immediately stop the work. Stop the engine and investigate the cause of the defect. Before proceeding, perform the necessary repairs.

9.8 Cleaning the Machine



If the machine is not cleaned, this will lead to increased wear. If the machine does not operate optimally, this can compromise the safety of the user.

Disadvantages associated with non-cleaning:

1. Increased wear on bearings
 2. Increase in sealing wear rate
 3. Reduced cooling efficiency
 4. Fire hazard
 5. Inability to detect fractures or cracks
 6. Damage to paint coating
 7. Stickers becoming illegible
- Each time after the machine is used, make it a habit to spend some time cleaning the machine. The cleaning of the machine can also be considered to be a visual check. This lets you detect cracks, breaks or lack of lubrication in time.

Special attention must be paid to the following items.

- The engine must remain free of dust and dirt. In particular, the cooling fins must be clean and the area around the exhaust pipe must be unobstructed. The area around the filler plug must also be kept clean so that dirt does not enter the fuel tank.
- The bearing bushes must be free of sand and dirt that sticks in the lubricant. After wiping down, reapply lubricant (see the list of lubricants in "read § 11.2 Maintenance schedule" on page 37).
- Using a dry cloth, remove any dirt from the chassis. Pay special attention to places where stickers with safety messages are displayed.
- Decals used to indicate safety messages, that are no longer legible must be immediately replaced. Obtain these original decals from your ELIET Dealer.



Caution:

Wear proper apparel when cleaning. Gloves are required.

- When cleaning, use a dry cloth, soft brush, etc. To remove grease, use penetrating oil containing molybdenum disulphide. This spray lubricates and also dissolves rust. (Do not use any cleaning products that affect paint or stickers.)
- Steam cleaning of the machine is permitted. However, never point the water jet for long periods in the direction of bearings, electric contacts or filler caps. Water is known to be the main cause of corrosion and must, therefore, be avoided at all times. Allow the engine to cool down prior to cleaning it down with a cold water spray.

10. Transporting the machine



- Make sure to clear the shredding chamber before moving the machine. Make sure the infeed opening is free of branchy material.
- When moving the machine over greater distances (over 2m - 78.74 Inches), always take care to turn off the engine.
- The chipper is designed to be in stationary position while working. This means that both the wheels and support legs are on the ground. To transport the machine you have to put it in transport position. To do this, grab the handle to the funnel and tilt the machine to the front till it is in a balanced position. (The handle is on + 60 cm - 23.622" City / 80 cm - 31.496 " Country of the ground).

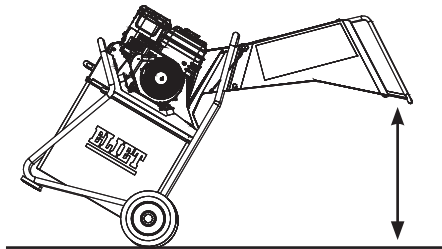

- Then, grasp the chassis upper tube with your left hand while holding the loading hopper handle with your right hand. In so doing, you can hold the machine with a firm grip for smooth pulling and pushing.
- Only adults may move or transport the machine.
- Also, during the transport, do not allow children, unauthorised persons or animals within a radius of 5 m - 196.85 Inches around the machine.
- The infeed hopper can be disassembled for an easier transportation of the machine in a car. ("read § 16.4 Dismantling the infeed hopper" on page 62) .
- To slide the wheel holder out of the frame, tilt the machine 15 cm - 6 inch over the support feet till the wheels are about 15 cm - 6 inch above the ground. Put your foot on the connection tube between the wheels and push it down out of the chassis. (First, check whether the wheel holder is not secured to the right lower side with a pressure screw (M8).

- Use slip resistant ramps to load the machine into a van or a trailer. Ensure that these are well secured to the vehicle or trailer.
- Assure yourself the parking brake of the vehicle is on before loading the machine.
- Under no circumstances must the angle of the ramp be greater than 25°.
- Be careful and composed when loading and unloading the shredder so that the machine does not tip over and give rise to an accident.
- In the event that the machine does tip over, right it again as soon as possible. This prevents oil from leaking out of the crankcase on to the air cleaner.
- Try to prevent the motor from falling over, since these filters are expensive.

- When walking up a slope push the chipper out in front of you with you facing uphill.

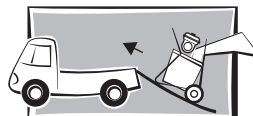

- When walking down a slope, move down backwards with you facing the machine.

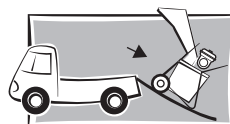

- The machine must be properly tied down within the vehicle during transport. Use the tube-gear to attach ropes.
- Do not overload the vehicle. "read § 13. Equipment Specifications" on page 54 to find out the exact weight of the shredder.
- The maximum allowable lateral slope angle amounts to 10°

11. Maintenance

11.1 General



For your information:

The dealer's personnel are always at your service. ELIET Dealers can always rely on comprehensive support from ELIET, so that they can work together to find a solution for any problem that you may have. For a repair or for the maintenance of the engine you can always contact your ELIET Dealer or an engine manufacturer authorized service centre. If you need to contact these services, the model and serial numbers must always be specified of both the machine and the engine, and also describe the problem in detail.



Caution:

Only use genuine ELIET replacement parts. These service parts are manufactured to the same strict quality control and degree of craftsmanship as the original equipment.

- For your own safety, only genuine service parts must be installed on the ELIET machines.

Perform maintenance in a room intended for this purpose. This area must have the following features.

- spacious
- easy access
- Well lit.
- Dust-free.
- clean and tidy.
- Quiet.

These characteristics are important to enable maintenance to be performed in an optimal manner.



Caution:

Maintenance performed in an incorrect manner may compromise the operator's safety.

- Maintenance should be always carried out with the engine turned off.
- Always wear safety gloves when performing maintenance. Safety goggles may be required for certain operations. These are supplied with the machine.

TIP:

The maintenance work described can essentially be performed by any person who possesses the requisite technical knowledge. However, ELIET recommend that the machine should be handed in to an ELIET dealer for a Prof 5 overhaul each year.

Your ELIET dealer is always at your service for maintenance and advice. He stocks genuine ELIET service parts and lubricants. His staff can always obtain advice and service from ELIET, so that they can provide you with an impeccable after-sales service.

11.2 Maintenance schedule

11.2.1 Routine maintenance before each operation:

- Visual check of the stat of the machine ("read § 11.3.1 Visual inspection" on page 38)
- Checking the engine's oil level ("read § 11.3.2 Checking the engine's oil level" on page 38)
- Cleaning the air filter ("read § 11.3.3 Cleaning the air filter" on page 39)
- Inspection of the blades ("read § 11.3.4 Routine check of the blades" on page 39)
- Grinding the blades ("read § 11.3.5 Grinding the blades." on page 41)

11.2.2 Maintenance after every 20 hours of operation:

- Reversing and/or replacing the blades ("read § 11.3.6 Reversing and changing chipper blades" on page 44)
- Cleaning the machine ("read § 9.8 Cleaning the Machine" on page 33)
- Changing the engine oil ("read § 11.3.7 Changing the engine oil" on page 50)
- Checking and/or changing the spark plug ("read § 11.3.8 Checking and/or changing the spark plug" on page 50)
- Changing the air filter ("read § 11.3.9 Changing the air filter" on page 51)
- General lubrication treatment ("read § 11.3.10 General lubrication treatment" on page 51)

Lubricants

Engine (0,6 l)

SUNOCO SUPER DENALUBE

SAE 20 W 50 API SF / CC

Bearings

NOVATIO PTFE OIL / PENETRATING OIL ON MoS2 base

Wheelaxle

SUNOCO VET MULTI-PURPOSE LR - EP2

11.3 Routine check prior to any operation



11.3.1 Visual inspection

Check that no parts have been deformed, that welded seams are not cracked and that parts are not excessively loose. If problems are found, carry out the necessary repairs first. Check that the machine is running at the correct rpm (3200 rpm) (an rpm counter can be obtained from you ELIET dealer). Never attempt to change the default settings of the engine.



11.3.2 Checking the engine's oil level

- Park the machine on a level surface so that the engine is perfectly horizontal.
- “read § 6. Main parts” on page 9. for the position of the oil drain and oil filler caps.
- Take a clean cloth and clean the surroundings of the filler cap.
- Turn loose the yellow oil filler cap on the right side of the engine.
- You can notice straight away if there is sufficient oil in the crankcase. The oil level should reach out to the edge of the filler neck. Is the oil not up to the edge of the filler neck, then there is insufficient oil in the crank case.
- If the oil level is too low just add some oil by fuel filler. Fill till the desired level is reached.
- To do this, use a funnel with a strainer.
- Only use the recommended oil (see manual engine).
- Immediately clean away any spilled oil.

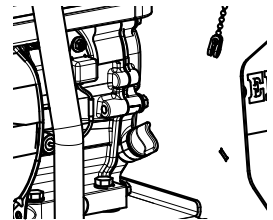

Caution:

Make sure no dirt goes into the crankcase along the filler cap



11.3.3 Cleaning the air filter

- The air filter is positioned behind the black cover above the ' Choke lever ' on the engine.
- This black cover is fixed with one wing bolt which one can easily unscrew by hand.
- The filter consists of two parts. First we have the pre-filter, which is made up of a sponge that sits around the filter cartridge. Second the actual air filter that just like a car, consists of laminated paper.
- Sponge filters can be cleaned by rinsing them with some petrol and blowing them with compressed air. (Blow from inside to outside)



Caution:

Do not come too close to the filter with the air pressure flow. There is a risk of micro-cracks that take away the filter-effect.

- Paper filters are cleaned by dusting them down or treating them with compressed air.
- After cleaning, replace all parts in their original positions.



Caution:

In the event the machine has toppled over for some reason, check the air filter immediately. The unusual position of the engine may have caused oil to seep from the crankcase via the carburettor onto the air filter. Oil on the filter paper obstructs the air passage. Soiled filters must be replaced immediately.

11.3.4 Routine check of the blades

Sharp chipping blades will give the machine optimum performance and provide maximum operating speed. Enhance your own work comfort by taking some time to check the blades, and if necessary, sharpen them.

SHARP BLADES = MAXIMUM OUTPUT

- Before performing any maintenance, stop the machine



Warning:

The blades may continue to rotate for a few seconds after the motor is switched off. Always check whether the blade shaft has come to a complete standstill.



Caution:

Always wear gloves since blades can be razor-sharp

- Open the chipping chamber (“read § 16.2 Opening and closing the chipping chamber” on page 59).

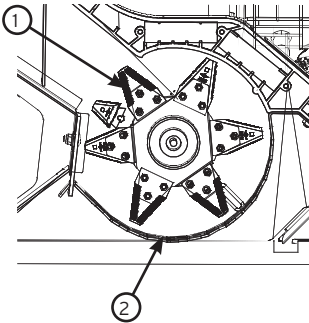

Pay particular attention to the following :

Garden waste chipping with the ELIET chipping system takes place in two steps. We first have the contact of the blades with the garden waste when chopping takes place where the cutting block can be found. The wood and garden waste is cut in large, rough and irregular chippings during this **primary chipping (1)**. These large chippings will, subsequently, end up in the chipping chamber where they are finely chopped to produce small chippings. This **secondary chipping (2)** will continue until the chippings are considered to be small enough to pass through the openings of the calibrating sieve.

Each of these chipping actions set certain criteria that the blades must meet for optimal chipping efficiency:

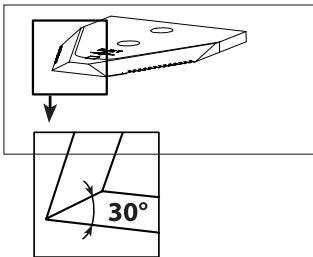

- A)** The top of the blade, in particular, is important with regard to the primary chipping. Since the blades act as splitting blades, the cutting angle is essential because this forms the key that will cleave through the wood. The **cutting angle** of the cutting edge of the blade is by preference 30°. The sharper the blade edge, the less resistance when splitting and the smaller the cutting impact on the structure. This will ensure considerably fewer vibrations and noise. This will also benefit the load on the blade shaft and the bearings. The blades must be regularly ground to guarantee the optimum cutting angle. (“read § 11.3.5 Grinding the blades.” on page 41)

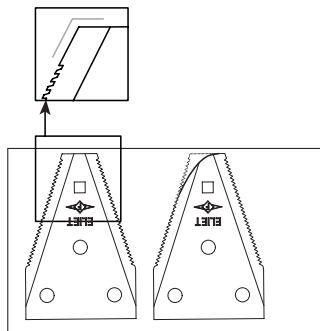

On the other hand, the form of the top of the blade is of essential importance for the performance and the speed of this primary chipping. The angle of the **top of the blade** will determine the angle at which the wood is pulled inside the chipping chamber. If this angle is rounded due to wear, the blades must be reversed and/or replaced. (“read § 11.3.6 Reversing and changing chipper blades” on page 44)

B) The issue is to have the chippings leave the chipping chamber as quickly as possible with regard to the secondary chipping. The chippings, therefore, must be quickly reduced until they are small enough to pass through the openings of the calibrating sieve. Every contact with the cutting area of one of the blades must, therefore, ensure that the chippings become smaller. Therefore, **the sharper the full active cutting edge** of the blades is, the more efficient chipping will be. Regular grinding of the cutting edge is, therefore, required.

Cutting edge teething ensures that the cutting power of the blades increases and the cutting edge remains sharp for a longer period of time. It is very important to never grind away the teeth when performing maintenance on the blades. (“read § 11.3.5 Grinding the blades.” on page 41)

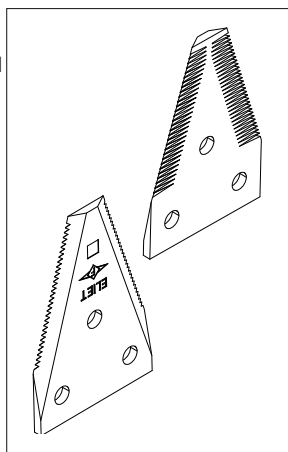

The position of the blades on the blade shaft has been selected very specifically to obtain an alternative chopping configuration with regard to primary chipping and the correct circulation of the chippings in the chipping chamber with regard to secondary chipping. You must, therefore, always ensure that you respect the original set-up when reversing or replacing blades. (“read § 11.3.6 Reversing and changing chipper blades” on page 44 where the rules are explained.)



11.3.5 Grinding the blades.

Correct and timely grinding of the chipping blades will extend blade life. (ELIET recommend the following : Grind after at least every 10 working hours.)

Preparatory warnings

- Always wear safety glasses and hearing protection when grinding blades. Wearing gloves is also mandatory when performing any maintenance.
- NEVER rotate the blade shaft by grabbing the blades. Use a tool to grab the blades.
- The blade has two cutting edges (reversible blade). This means that you must take into account

when grinding that there is another razor-sharp blade side.

- Open the chipping chamber (see Annex 2).
- Remove the blade shaft from the machine to grind blades (see annex 3).
- For safety's sake, firmly clamp the blade shaft (i.e. In-between a bench vice) and ensure that this cannot twist, move or fall unexpectedly during maintenance and, thus, injure someone.



For your information :

The blades do not have to be disassembled for grinding. Use for this a small angle grinder equipped with a grinding disc suitable for steel.

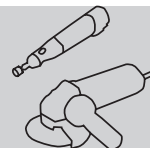

Caution :

Lit sparks will fly around when grinding the blades. They may start a fire. Bear this in mind when selecting the work site. Never grind blades near fuel or lightly flammable products. Always have available a fire extinguishing resource in the immediate vicinity.

A blade has two sides.

- The front of the blade has the two chamfered cutting edges. **(V)**
- The rear clearly shows the tooth profiling of the cutting area. **(A)**

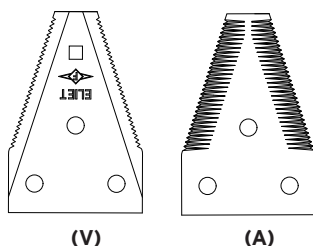

As described in § 11.3.4, Checking the blades, a sharp blade edge and a correct cutting angle are essential for efficient chipping. Blades must be correctly ground to ensure these two features can be realised.

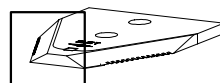

- If blades become blunt, the sharp cutting edge will become worn and will be upset to form a wider rib. **(1)**
- By grinding a little metal from the cutting edge, you can again obtain a sharp cutting edge from this wide rib. **(2)**
- Grinding is performed by moving the grinding disc along the angled cutting edge.
- Note : By regularly grinding, you will only have to grind away a small adjustment of the metal each time to again obtain a sharp cutting edge. This will ensure for very short grinding times and you will always have the best possible cutting edge. (ELIET recommend the following : Every 10 working hours.)
- Avoid grinding at the same location for a longer period of time. This will prevent local discolouration of the blades, which would indicate heating and, therefore, the material structure at these places will change and the hardness will decrease.
- It is extremely important that the existing cutting angle be respected when grinding. **(3 : Incorrectly ground blade)**

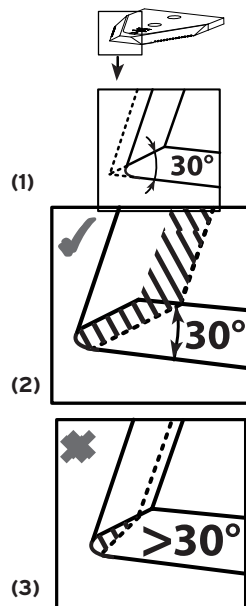

- If the cutting angle is not maintained, blades will be stopped in the wood due to a blunt angle **(4)** of an interrupted cutting angle **(5)** and a lot of power will be lost. Too sharp a cutting angle **(6, 7)** will give rise to a weakened cutting edge and, therefore, blade life will be considerably shortened (see figures 4, 5, 6 and 7).

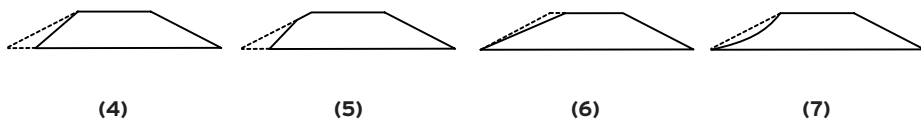

- Never grind the rear side of a blade. The profiling is on the rear with regard to RESIST/6™ blades. If you grind away the teeth, the blade will lose a great deal of its cutting force.
- The top of the blade is subjected to the heaviest loads during chipping. You should, therefore, grind them as little as possible to avoid weakening.

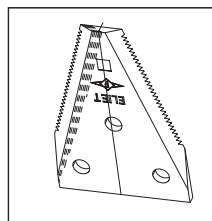

- After all, a little of the material is removed every time they are ground and, therefore, the active cutting edge becomes smaller. You can continue grinding up to halfway the width of the blade tip. If you exceed this limit, you will be compromising blade life of the unused cutting edge. We recommend reversing the blades at this point ("read § 11.3.6 Reversing and changing chipper blades" on page 44).

- If the tip of the blade is rounded-off, chipping efficiency will be reduced. In this event, further grinding of the blade serves no purpose. This is the time to reverse or replace the blades. (“read § 11.3.6 Reversing and changing chipper blades” on page 44).
- After grinding, refit the blade shaft into the machine. (“read § 16.3 Removing and reinstalling the blade shaft” on page 60.)
- Carefully close the chipping chamber after grinding. (“read § 16.2 Opening and closing the chipping chamber” on page 59)

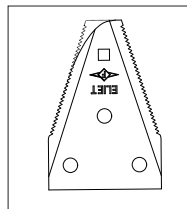

11.3.6 Reversing and changing chipper blades

If the blades are regularly ground, a blade life of more than 50 hours can be guaranteed per cutting edge. When one cutting edge is totally used, you can reverse the blade and you will have another 50 hours. If both blade edges are worn, replace the blade as a whole.



Caution :

Any entitlement to claim on the guarantee will be excluded in case of damage or consequential damage that occurs due to faulty maintenance of the blades. Consult your official ELIET dealer for advice if required.

11.3.6.1 Work method for reversing the blades



Warning:

Wear protective gloves as the blades are razor sharp!

- Stop the machine and disconnect the power supply extension cable from the machine.



Warning :

The blades may continue to rotate for a few seconds after the motor is switched off. Always check whether the blade shaft has come to a complete standstill.

- Open the chipping chamber (“read § 16.2 Opening and closing the chipping chamber” on page 59)
- Remove the blade shaft from the machine to reverse the blades. (“read § 16.3 Removing and reinstalling the blade shaft” on page 60.)
- For safety's sake, firmly clamp the blade shaft (i.e. In-between a bench vice) and ensure that this cannot twist, move or fall unexpectedly during maintenance and, thus, injure someone.

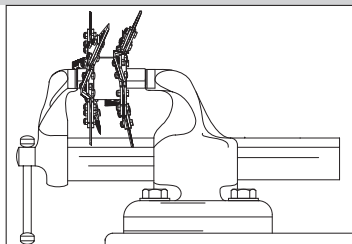

- There are a few rules that must be respected for reversing or replacing the blades. First we will examine in detail the construction of the blade shaft to understand the logic behind the rules:
- A Maestro City/Country blade shaft has been constructed from two identical blade discs that each contain 6 blades.
- Although the blade discs are identical, they are offset 90 degrees from each other around the central shaft.
- The two blade discs have been welded on the central shaft. This shaft is not symmetrically positioned with regard to the volume of the two blade discs:

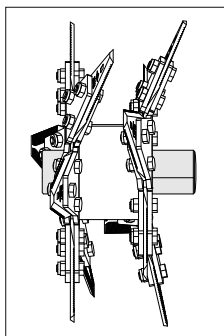
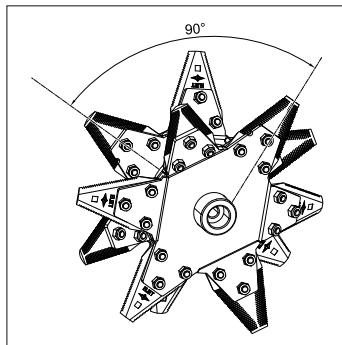

- On one side, there is a long protruding shaft section in which a large bore is provided that is meant for sliding on the motor shaft: This side will be referred to as follows from now on : The **motor side (M)**” of the blade shaft.
- On the other side, there is a short protruding shaft section This is the place where the retaining screw is placed to fix the blade axle on to the crankshaft of the engine. We refer to this side as : The **tightening side (O)** of the blade shaft.

- Take note that each blade has two sides.
Front (F) :The side with the chamfered cutting edge.
Back (R) : Side with the clearly visible tooth profile.

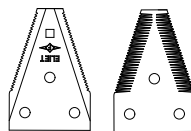

- It catches our attention that the orientation of each blade is different on the blade disc. A special order is involved when positioning blades. We recommend numbering the blade positions to ensure the order is respected when the blades are reversed.

- Blade discs can occupy six different positions. Therefore, the **blades** and the **matching positions** must be numbered from 1 to 6 on the blade holder using a pen.

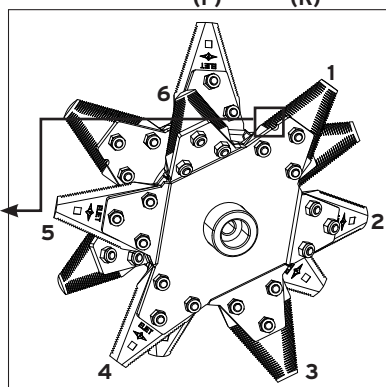
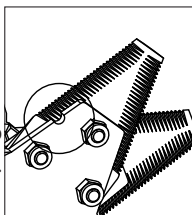

- Always start numbering in clockwise direction (as viewed from the “tightening side”) from the right blade position that has a small recess.
- Do the same for the second blade disc.

Each blade is held in place with three M6 bolts. Fully loosen the nuts of each blade and remove the bolts.



For your information :

Remove and refit one blade at a time. This ensures that reversal is performed in an orderly manner.

TIP : There are 36 bolt connections in each blade shaft. ELIET recommend using a pneumatic ratchet wrench to quickly loosen these. Place a ring spanner on the bolt head and loosen the nut using the ratchet wrench ratchet. (SW 10)



Caution :

If you loosen the bolt connections manually, avoid injuries to hands by using two ring spanners with long handles. (SW 10)

- Replace damaged bolts and nuts immediately. (Part Nr. bolt : BS 511 000 618 ; nut : BS 502 000 600)
- Do not pull away the blades using your hands but use a self-grip wrench.
- It is useful to put a wedge (screwdriver) in-between the blade discs to ensure it is easy to release them.
- Rotate the blade numbered 1 through 180° and fit it into position 4. Rotate the released blade 4 through 180° back into position 1.
- Rotate the blade numbered 2 through 180° and fit it into position 6. Rotate the released blade 6 through 180° back into position 2.
- Rotate the blade numbered 3 through 180° and fit it into position 5. Rotate the released blade 5 through 180° back into position 3.

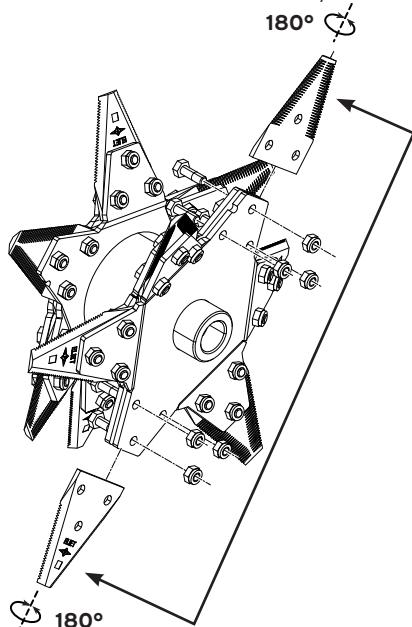

Repeat this procedure for the second blade disc.

- Always make sure to refit the bolts in the blade holders in such a way as to ensure the nuts are on the **tightening side**. This will ensure the direction of rotation to secure the blade shaft against loosening.

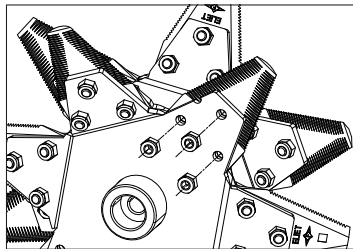

Caution :

After reversing the chipping blades, always check the bolts for correct tightness after expiry of the first 5 hour run. Ignoring this operation may cause serious injury and may even lead to death. The machine may also be significantly damaged.

11.3.6.2 Work method for replacing the blades

New sets of blades are available from your ELIET dealer under the following part number :
BU 401 100 102

- Stop the machine and disconnect the power supply extension cable from the machine.



Warning :

The blades may continue to rotate for a few seconds after the motor is switched off. Always check whether the blade shaft has come to a complete standstill before removing the chipping chamber cover.

- Open the chipping chamber (“read § 16.2 Opening and closing the chipping chamber” on page 59).



Warning :

Wear protective gloves as the blades are razor sharp!

- Remove the blade shaft from the machine to replace the blades (see annex 3).
- For safety's sake, firmly clamp the blade shaft (i.e. In-between a bench vice) and ensure that this cannot twist, move or fall unexpectedly during maintenance and, thus, injure someone.
- When replacing the chipping blades, simply remove the old ones and replace them with new items.

You may not simply randomly reinstall the blades. A specific order needs to be respected.

- Number the blade positions on the blade disc from 1 to 6 to ensure mistakes cannot be made. Start numbering with the right blade position that shows a notch and number clockwise (as viewed from the tightening side).
- Next, position the new blades as indicated in the drawing below. Keep the position of sides F and R in mind.

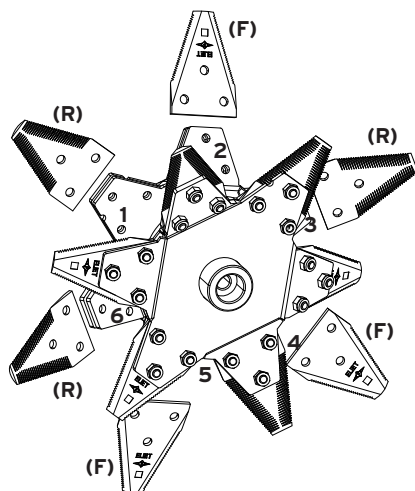
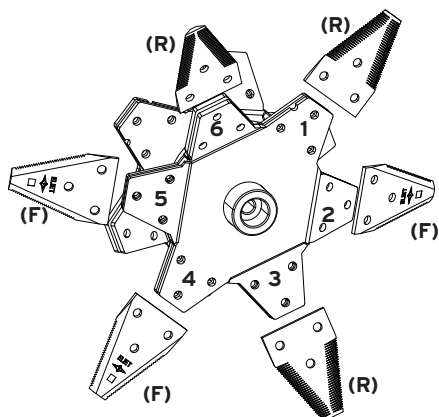
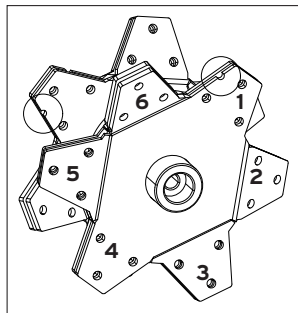

- Before fitting a new blade in between the two blade discs, first remove any dirt that may have built up between both mating discs.

TIP : To do so, use a stripping knife and compressed air.

- Always fit new bolts and nuts when replacing chipping blades. (This will also have been supplied when ordering a blade set.)
- Always make sure to refit the bolts in the blade holders in such a way as to ensure the nuts are on the **tightening side**. This will ensure the direction of rotation to secure the blade shaft against loosening.

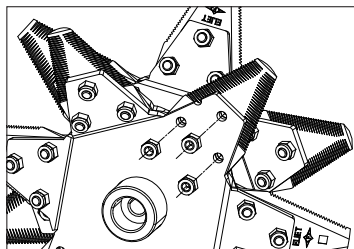

Caution :

Incorrectly or poorly installed blades may lead to breakdowns or damage to the machine. Operators and bystanders are also put at risk.

- Follow the same procedure for the second blade plate.
- Perform a check to verify whether the blades have been installed correctly: Apply the following rules :
 1. All blades (2 per blade disc that have been positioned at an angle on the blade disc and are oriented towards the wall of the chipping chamber must always be pointing with their back (R) towards this wall.
 2. The blades (2 per blade disc) that have been positioned at an angle and are oriented towards the adjacent blade disc must always have their backs (R) directed towards the other blade disc.
 3. The blades that are in the straight position (2 per blade disc) must alternate between being oriented towards the left and the right.
- When refitting the chipping blades check that all bolts are tight.
- Since the large number of retaining bolts, it is a good practice to check the bolts for correct tightness before fitting the blade shaft. Mark a position using a pen on the nut so that you are sure that they have all been tightened.
- The next time you start chipping, consideration should be given that new chipping blades take time to stabilise. This means that the bolts will probably loose tension which, in turn, means that certain blades will again become loose between the plates. **Thus, retighten the blade bolts within the first 5 operating hours of the machine. (Torque loading 10 Nm)**

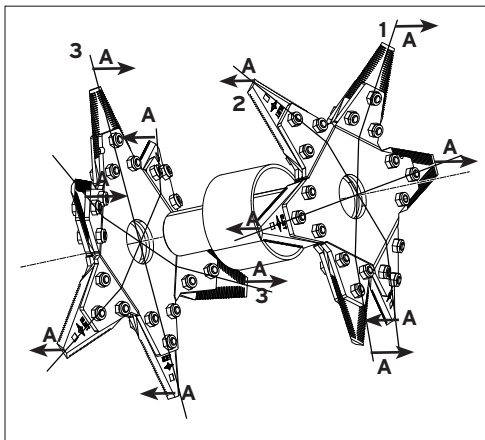

Caution :

After replacing the chipping blades, always check the bolts for correct tightness after expiry of the first 5 hour run. Failing to do this may have serious consequences for the operator and for the machine.



11.3.7 Changing the engine oil

- Ensure that the engine is on an even surface and turned off.
- At the rear of the engine, below the engine base, a plug is screwed into the crankcase (see the engine manual).
- Get a one litre collection reservoir before unscrewing the plug.
- Empty the full contents (approx. 0,6 l - 0.158 US Gallon) from the engine. There is a hole in the motor plate so that the oil can be easily captured on the bottom of machine.
- Replace the plug. Wipe away any spilled oil with a clean cloth.
- Refill the engine with fresh 4 stroke oil. ELIET recommends a top quality high-detergent oil:
- SUNOCO DENALUBE SAE 20W50 API SF / CC.
- Fill 0.6 l - 0.158 US Gallon oil by the filler cap until the oil reaches the edge of the filler neck.
- Wipe away any spilled oil with a clean cloth.



Warning:

Oil shortage causes severe engine damage.



11.3.8 Checking and/or changing the spark plug

- Turn off the engine and let it cool down.
- To easily reach the spark plug, remove the cover of the air filter.
- Clean the area around the fuel cap and remove the spark plug from the cylinder head.
- Using a feeler gauge, check whether the distance between the electrodes is correct (see engine manual)
- If the spark plug shows heavy deposits or is very dirty, it has to be replaced.

Take the following steps to verify ignition quality:

1. Put the spark plug cap back on.
2. Grab the rubber of the spark plug cap and press the outermost electrode against the mass of the engine.
3. Pull the starter cord.
4. Check for sparks between the electrodes.
5. The spark plug is in good condition if the sparks are clear and neatly centred between the electrodes.
6. Weak, irregular and not well-centred sparks indicate that the spark plug must be replaced
7. Consult the manual for the correct spark plug type.

**Caution:**

Fitting or changing a spark plug must be done with utmost caution so as not to damage the screw thread in the engine.

**Caution:**

Avoid dirt getting into the engine by the spark-plug opening.

- Secure the spark plug with a torque of 20Nm..



11.3.9 Changing the air filter

This procedure is exactly the same as for cleaning the air filter (“read § 11.3.3 Cleaning the air filter” on page 39).

New, suitable air filters are available from your ELIET dealer or an authorised service centre of the relevant engine brand. Read the engine manual for the correct type.



11.3.10 General lubrication treatment

ELIET is committed to using high-quality materials that extend a machine's life cycle despite the sometimes extreme work circumstances in which chippers are being used. For this reason, special lubrication products have already been applied in the factory.

These parts need lubrication :

1. Wheel axles
2. Conduction of the collection bag
3. Bearing or blade shaft support ring
4. Bolts for fixation infeed hopper

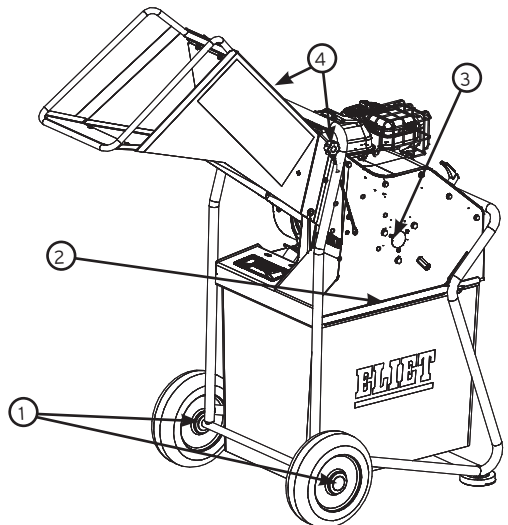

**Caution:**

The engine is turned off for the lubrication of the machine. Disconnect the spark plug. Gloves are mandatory, as the blades are razor sharp and can cause serious injuries.

Spray with penetrating oil or a spray based on MoS₂ on the zones to loosen old lubricant and to reduce any corrosion.

Wipe with a cloth all remnants of penetrating oil, dirt and old grease away. Purify everything as much as possible.

Then apply the new lubricant. Preferably use a lubricating spray Teflon (PTFE) based.

12. Winterizing the machine



- Clean the machine (“read § 9.8 Cleaning the Machine” on page 33).
- When storing the machine for long periods, it is recommended to perform the following steps.
- Conduct a major overhaul (“read § 11.2 Maintenance schedule” on page 37).
- Check all nuts and bolts for correct tightness. Checking most bolts for correct tightness simply involves the use of two sets of open-ended spanners (10, 13 and 17) and a set of Allen wrenches 4, 5 and 6
- Drain the fuel tank. Simply run the engine until the fuel tank is out of fuel and the engine stops.
- Alternatively, use a siphoning kit to dispense the remaining petrol in the jerry can (“read § 9.2 Filling up with Petrol” on page 25).
- Remove the spark plug (“read § 11.3.8 Checking and/or changing the spark plug” on page 50). Spray some penetrating oil containing molybdenum disulphide into the cylinder through the spark plug hole. Then pull on the starter cord for the piston to reach the top of its stroke. Refit the spark plug.
- Places where the paint coating is damaged are repainted or covered with grease in order to prevent rust. ELIET original paints are available from your ELIET Dealer.
- Store the machine in a dry place that is protected against rain, and if necessary, cover it with a tarpaulin.
- Never keep the machine in a place where it can come into contact with a naked flame source.
- Always allow the machine to cool down before storage.
- If the machine is to be stored outside, it must be well protected with a tarpaulin.
- Ensure that water does not directly fall onto the machine. ELIET strongly recommend that the machine is stored at a location that is well protected from the weather, etc.

13. Equipment Specifications



	Maestro City	Maestro Country
Shreddable timber diameter	40 mm / 1 1/2 "	45 mm / 1 3/4 "
Chopping speed (cuts/min)	36.000	36.000
Capacity (wheelbarrows/h)	10	14
Blades	12 ELIET Resist™ knives reversible	12 ELIET Resist™ knives reversible
Infeed height	1050 mm / 41"	1200 mm / 47"
Collecting box capacity	60 litres / 16 US gallon	80 litres / 21 US gallon
Storage dimensions	740x650x910 mm / 29x26x36"	740x650x1050 mm / 29x26x41"
Dimensions	1360x650x1260 mm/ 54x26x50"	1360x650x1400 mm/54x26x55"
Weight	63 kg / 139 lbs	63 kg / 139 lbs

14. EC Declaration of Conformity

Machine: **Shredder**
Model number: **ELIET MAESTRO CITY / ELIET MAESTRO COUNTRY**
Type: **MA 001 052 123**
MA 001 052 922
MA 001 053 124
MA 001 053 922

This machine has been designed and manufactured to comply with the following European CE regulations:

“EN 13683:Garden Equipment -Integrally powered shredders/chippers -Safety”

ELIET machine factory hereby declares that after performing a hazard analysis, it is fully aware of the potential hazards and risks associated with the machine. In this knowledge, the necessary steps have been taken in line with Machine Directive 2006/42/EG in order to ensure absolute operator safety for the operator, when the machine is used correctly.

The assessment of the sound power level and the guaranteed sound power level as determined in European Directive 2000/14/EG annex III/B 50 was carried out in accordance with the measurement instructions of EN 13683.

Measured sound power level: City: 110 dB(A) Country: 111 dB(A)
Guaranteed sound power level: City: 11 dB(A) Country: 112 dB(A)

Date: 01/2018
Signature:



Frederic LIETAER
CEO ELIET EUROPE NV

ELIET EUROPE NV
Diesveldstraat 2
B - 8553 Otegem
Belgium
Tel: +32 56 77 70 88
Fax:+32 56 77 52 13
E-mail: info@eliet.be

15. Warranty conditions

Dear Customer,

Thank you for placing your confidence in ELIET. We are convinced that the appliance you have chosen will fulfil your needs and expectations over the coming years. ELIET is committed to guaranteeing the good performance of its products.

What is warranty ?

ELIET's product design and manufacture procedures are subject to strict quality guidelines, aimed at **guaranteeing** a long product life and permanent safety. To ensure this, ELIET will repair any **hidden defects or abnormalities** throughout the warranty period, provided you **use your machine as instructed**.

Warranty conditions

ELIET's warranty obligations for new machines is governed by the following conditions.

I. Warranty period

The warranty period starts the day the dealer delivers the machine to the customer (date of invoice) and expires

- After two years of private use.
 - After twelve months or 100 running hours* of rental use.
 - After twelve months or 100 running hours* in semi-professional or in professional use.
- To be eligible to obtain warranty the customer is invited to register the newly purchased machine with ELIET. You should complete the registration online on Eliet's website : **www.eliyet.eu**

* what is reached first

II. Non-applicability of the warranty

- Wearing parts like knives, bearings, belts, chains, cogwheels, tires, lamps, fuses, etc. are not covered by the warranty.
- When the defect is shown to be caused by improper handling, improper use, negligence or consequential damage that occurs as a result of external influences (fall, broken stones, foreign object, accident).
- When the defect is shown to be caused by a lack of periodic maintenance or cleaning in accordance with the prescribed periodic maintenance.
- If it turns out that the defect was caused by acting against the instructions or advice of the user manual in.
- When the defect occurs after a repair by an unofficial ELIET dealer or a repair using parts that are not original ELIET parts.
- When the defect is shown to be due to the unauthorized modification of the machine's original construction.
- When the defect occurs after use of the machine contravening the instructions for use in the manual.

- When the warranty procedure is not followed or after the end of the warranty term.
- For all problems relating to the motor, please contact an authorized service centre of the engine manufacturer.

III. Procedure

- **Step 1:** On the date of purchase, the customer should register his/her purchase online by completing the registration card at **www.eliyet.eu**.
- **Step 2:** In the event of a defect becoming apparent, the customer shall have this verified by the authorized ELIET dealer. If the dealer feels that there is a factory defect, the dealer may invoke the warranty, under the terms specified.
- **Step 3:** Every warranty application must be accompanied by a fully completed official application form. Copies of this warranty application are available to dealers at ELIET or even at an importer/agent.
- **Step 4:** The dealer then orders the parts needed to perform the repairs. Next, the dealer faxes the order form together with the completed warranty form.
- **Step 5:** The warranty form should be stapled to the purchase invoice and mailed to ELIET or an importer/agent of ELIET.
- **Step 6:** ELIET will send the parts ordered to the dealer under the regular delivery and payment conditions.
- **Step 7:** The defective part will be examined by the technical department first prior to approving or rejecting the warranty. ELIET reserve the right to solely decide whether or not the customer has complied with the conditions for the validity of this warranty, i.e. 1 year or 2 years. Faulty components shall become the property of ELIET.
- **Step 8:** When a warranty claim is found to be valid, ELIET will credit the warranty parts. Customers shall never be entitled to apply for a refund of labour costs.

IV. In case of damage caused by transport

- All goods are supplied ex factory. Transport risks are borne by the customer. It follows, that ELIET highly recommend to check the goods for damage on arrival.
- Any damage found should be stated on the delivery form before signing. Make sure the driver of the haulage company puts his signature next to the damage on your copy.
- In the absence of a written and signed declaration on the delivery form, the insurance of the haulage company will not accept any liability.
- Damages can be claimed from the hauler using a copy of the delivery form and a covering letter stating your complaint.
- The damaged machine should be kept in its original condition until the hauler's insurer has performed any examination.

16. Annexes

16.1 Hazard analysis

Below you will find a list of dangers and risks that are linked to storing away, transporting or using the chipper. Take note of these dangers and avoid these risks by following the instructions contained in this manual. Be aware that it is not just the user who runs a risk but also third parties can be exposed to these risks. Ensure that bystanders are always kept at a safe distance.

- Injury to hands due to reaching into the infeed opening past the anti-projection flaps.
- Danger of suffering heavy injuries or death because a machine part (blades, bolts, etc.) have become loose because there has been a lack of checking and maintenance.
- Danger of suffering injuries due to projection along the feed and discharge sides after a foreign object has been introduced (stone, metal, textile, PVC, etc.).
- Injuries caused by chippings flying out from the discharge opening when the machine is in operation.
- Cutting injuries to hands due to injury from the blade shaft coasting to a stop on opening the chipping chamber.
- Cutting injuries to hands when disassembling the blade shaft.
- Cutting injuries due to the blade shaft falling after being disassembled.
- Strangulation or constriction by loose clothing getting caught in moving parts.
- Injuries caused by the machine tipping due to unsafe transport.
- Danger of suffering burns due to chippings and wood residue that is blocking the cooling air ducts.
- Irritation of the airways or lung problems due to inhaling the dust produced.
- Hearing disorder due to insufficient protection of the ears during the work.
- Bruising or injury when feeding materials, due to the power of the blades on the wood.
- Bruising or injury due to the kick-back of wood when being introduced in the feeding hopper.
- Mental disturbance or rheumatic disorder due to shredding for a long time at a time without taking breaks.
- Joint pain due to vibration transfer when continuously inserting thick branches.
- Injuries following contact with the blades for blockage clearance, maintenance or cleaning the machine.
- Back problems caused by lifting the machine in an irresponsible way..
- Injury due to a fall while driving over a substrate that cannot carry the weight of a person and machine.

This is not a comprehensive list and is provided for information purposes only to safeguard the safety of the user.

16.2 Opening and closing the chipping chamber

16.2.1 Opening the chipping chamber

1. First remove the collection bag out of the machine to get access to the sieve
2. Turn the lever (1) to loosen the lock on the screen. If the lever is completely loose, press on the handle. This way the screen comes out of its seat and can be taken out of the machine.

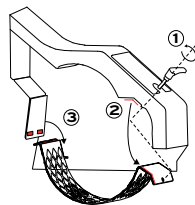

Warning:

The blades are razor sharp, avoid injuries and wear gloves!

3. To get a better view on the situation in the shredding chamber, and to be able to empty the shredding chamber easily, tilt the machine over the front wheels till the funnel rests on the ground.

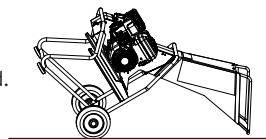

Caution :

Be attentive when tilting the machine that no gasoline is leaking away from the gas tank.

16.2.2 Closing the chipping chamber

In order to remount the screen, slide the two protruding parts in the provided slots on the front of the machine. Then tilt the screen in the chipping chamber and press it against its seat. The screen hooks behind the edge of the chamber wall. Now turn the lever to tighten the sieve again. Turn the lever till sufficient tension is built up.

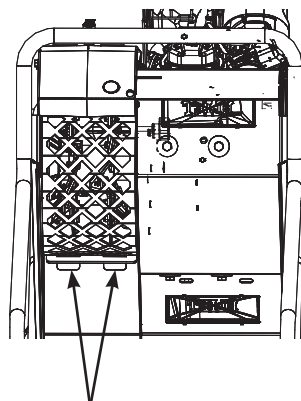

16.3 Removing and reinstalling the blade shaft



Caution:

Always switch off the engine prior to removing the blade shaft. Let it cool down sufficiently so that in the event of contact with the engine there occurs no danger of burns.



Warning :

To perform this maintenance, you are exposed to the blades. Protect yourself against the risks and wear safety gloves.

Before removing the blade axle, slide the collection bag out of the machine and remove the sieve ("read § 16.3 Removing and reinstalling the blade shaft" on page 60)

If necessary, remove the chips from the shredding chamber.

The blade shaft is mounted on the crankshaft of the engine and is thus borne by the engine. In the case of the engine, the suspension of the blade depends on the model:

- In the **Maestro City** the blade axle is not supported. At the end of the blade shaft, a nylon ring that serves as a support cushion is installed. This nylon ring holds the blade shaft in position when it is under pressure and has been pushed to far out of its centre line. In normal operation there is no contact, there is an air gap between this ring and the end of the blade shaft.
- In the **Maestro Country** the engine supports on 4 rubber vibration dampers. By the agility of the engine under the influence of these dampers the blade shaft is fixed at the opposite side in a bearing. This bearing in its turn is mounted in a fixed bearing support.

To disassemble the blade shaft, first dismantle the bearing-support (Country) or the nylon support ring (City). To do this, loosen the three (1) M8 bolts (key size 13) or the three M6 bolts (key size 10).

Remove the rubber protection cap (2) in the right side of the shredding chamber to gain access to the central clamping bolt of the blade shaft. Turn this clamping bolt (key size 17) counterclockwise and remove it from the machine.

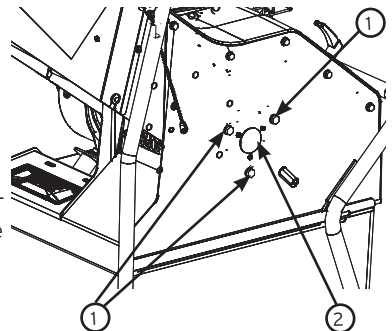

Now you can loosen the engine mounting plate from the frame. To do so, loosen the four M8 (3) bolts completely. The engine and its fixing plate are no longer attached to the chassis.

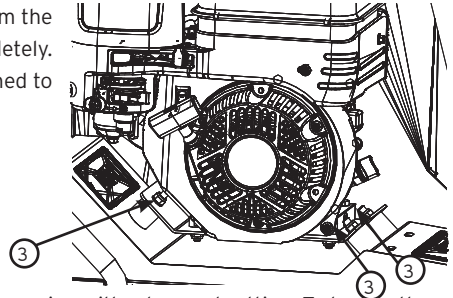

The blade shaft is attached to the crankshaft of the engine with a tapered setting. To loosen the blade axle from the crankshaft, screw thread (M12) is provided on the top of the blade axle. Screw a bolt (M12x130) in this hole. Screw the bolt manually till you feel it makes contact with the end of the crankshaft. By turning it further into the blade shaft, you will feel the blade axle coming loose.

Once the clamping force is gone, you can slide the blade axle from the crankshaft. Grab the blade axle between two blade plates at its core, and hold it up. Now slide the engine away to the left, so that the crankshaft is completely out of the hub of the blade axle.

Remove the blade axle from the machine by the output zone



For your information :

After disassembling the blade shaft, any corrosion on the axle will be sanded away, so that the shaft is clean for assembly.

Check if the nylon support ring (City) doesn't show any signs of wear. Replace it if needed: Stock number : MPA 01 221 470 . Check the bearing and the bearing holder for signs of wear at the Country version. Replace them if needed: Stock number bearing : BL 002 004 703, Stock number bearing holder: BR 692 047 290.

When reassembling the blade shaft be ensured that the lower bearing support (Country) or nylon support ring (City) is already mounted on the shaft end of the blade shaft before reinserting it in the shredding Chamber.

Now slide the crankshaft of the engine in the hub of the blade shaft until it is clamped on the tapered shaft. Tighten the clamp bolt back in to the central part at the end of the blade shaft. Tighten this clamp bolt securely (wrench 13).

Now reassemble the nylon support ring (City) and screw it tight. Caution: Do not put too much tension on the screws so that the screw thread doesn't tear.

Place the rubber cover back into the opening. In case of a Country, reassemble the bearing support but do not fix the bolts very tightly.

Now shift the engine so that the blade shaft is central in the shredding room, and the distance between the two outer knives is equal on both sides.

Place the clamping bolts back in the engine plate. Turn the bolts till the moment where there is no tension on the bolts. Now, see if the blade shaft is aligned relative to the Central nylon support block. The air gap between the blade shaft and nylon support block must be equal everywhere. If not, rotate the engine a little to adjust this. In a case of a Country, one will also examine if the bearing is aligned tension free. Here one can also adjust the position engine. Then tighten the three clamping bolts of the bearing support firmly. Now you tighten the fixing bolts of the engine securely.

16.4 Dismantling the infeed hopper

For easy transporting of the machine in a car or other vehicle, the loading hopper can be dismantled.

Screw both screws bolts out of each side of the hopper, first screw out the left bolt, afterwards the right one.

The engine should be turned off for this maintenance. Once the screws are gone, the funnel can be removed. Support the hopper with you right hand, while lifting the hopper out of its position with your left hand.

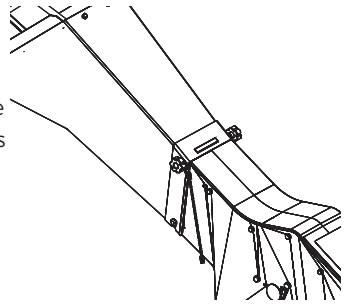

Caution :

Be careful when putting the hopper on the ground. Don't drop it. This could severely deform the hopper, making it no longer fit correctly on the machine.

