

*Made in Italy*



# CATALOGUE

POWERED by  
**HONDA**™

[www.ecotechitalia.com](http://www.ecotechitalia.com)

SWING  
PATENTED  
SYSTEM

## SWING SYSTEM

*THE PATENTED SWING SYSTEM MAKES IT POSSIBLE TO WORK ON SLOPES OF UP TO 45° WITH 4-STROKE ENGINE. THIS SYSTEM ALLOWS YOU TO AUTOMATICALLY SET THE ENGINE SWING AT VARIOUS POSITIONS ON THE RIGHT AND ON THE LEFT, THUS MAINTAINING A HORIZONTAL POSITION, IMPROVING STABILITY AND AVOIDING SEIZING. THE INCLINATION IS ADJUSTED BY MEANS OF A SIMPLE AND CONVENIENT CONTROL PLACED ON THE HANDLEBARS.*

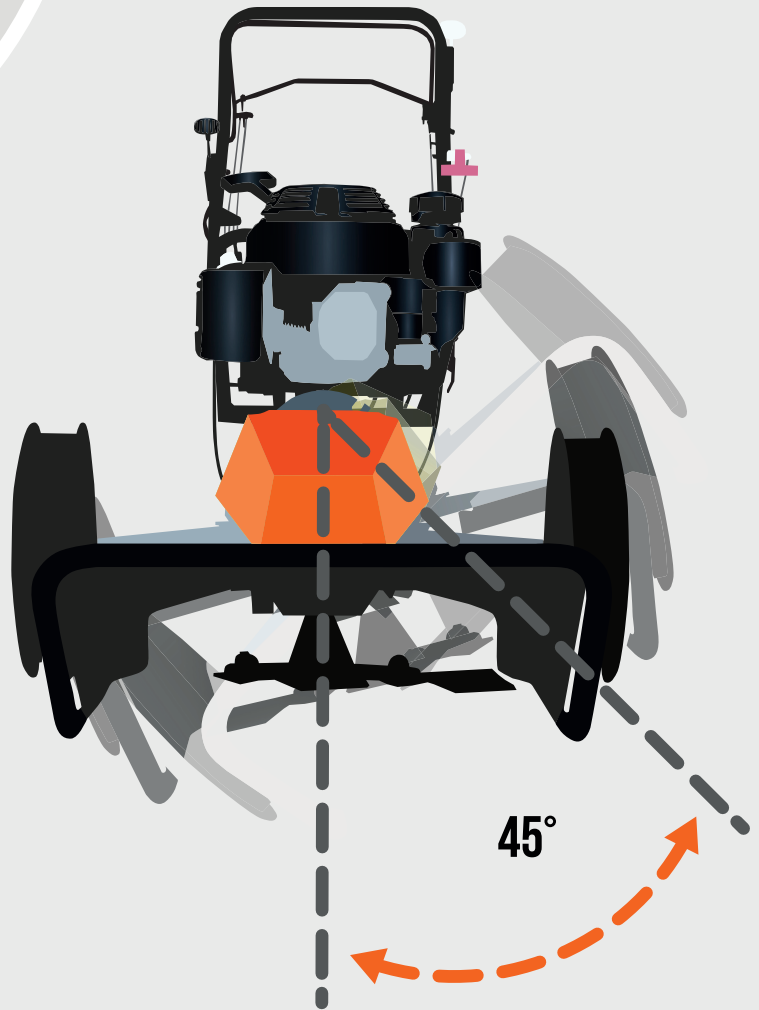

# CONTENTS

SWING SYSTEM ..... 2



60 SERIES ..... 4

DCS 60  
DCS 60 TRACTION  
TRT 60

ML SERIES: LAWN MOWERS WITH INTER-CHANGEABLE CUTTER HEADS ..... 8

ML 60 SWING  
CUTTING DECKS

HYDROSTATIC SERIES ..... 11

HSR 110  
HSR 135 SWING

HSR 110  
11



# 60 SERIES

Our 60 series includes string trimmers, forestry mowers and mulchers to meet and satisfy all the demands and for any type of cutting. All with a 4-stroke Honda petrol engine, belt and mechanical drive (excluding DCS 60), adjustable cutting height of 20 - 100 mm, maximum cutting width of 600 mm.



**DCS 60** (COD. 020)  
*WALK-BEHIND STRING TRIMMER*



**DCS 60 TRACTION** (COD. 021)  
*DRIVE WALK-BEHIND BRUSH-CUTTER*



## OPTIONAL ACCESSORIES

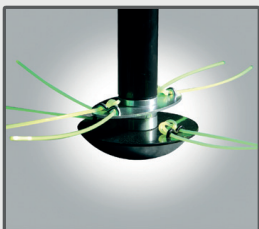

*Double cutting head*



*Extra strong string # 20 / 50 items*



*13" steel crawler wheels*



*#4/8 Hardened steel blades*



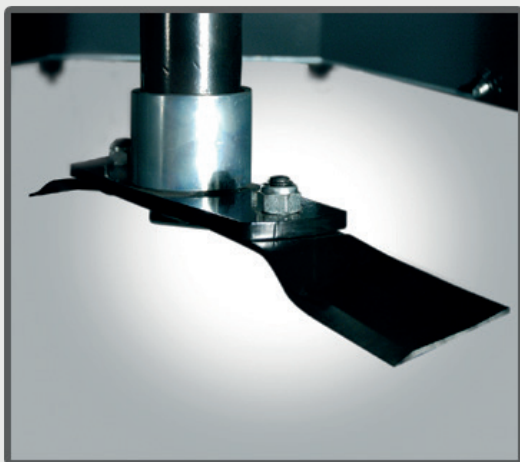

*Swinging floating blade*



*Adjustable rear discharge plate*



**TRT 60** (COD. 042)  
*DRIVE FORESTRY MOWER*

**TECHNICAL DATA**

<i>Engine</i>
<i>Displacement</i>
<i>Transmission</i>
<i>Gears</i>
<i>Speed</i>
<i>Wheels</i>
<i>Track</i>
<i>Cutting height</i>
<i>Cutting width</i>
<i>Dry weight</i>
<i>Guaranteed sound pressure Lwa</i>

**DETAILS**

*Adjustable handlebar*





DCS 60	DCS 60 TRACTION	TRT 60
	Honda GCV 200	
	201 cc	
--		<i>Mechanical</i>
--		1
--		1,6 km/h
16"		13" <i>pneumatic</i>
600 mm		580 mm
30 - 45 - 60 mm	30 - 45 - 60 mm	20 → 100 mm
max 600 mm	max 600 mm	500 mm
33 Kg	38 Kg	50 Kg
98 dB	98 dB	96 dB



# ML MULTI-USE SERIES



## ML 60 SWING (COD. 056)

- WHEEL EXTENSION ADJUSTMENT
- TILTING ENGINE PLATFORM
- SUITABLE FOR SLOPES UP TO 45°
- INTER-CHANGEABLE CUTTER HEAD OPTIONS

## DETAILS

### FAST CHANGE CUTTING DECKS

The different cutting decks can be quickly and safely changed using a simple power take-off (PTO).





Our series of mowers with inter-changeable fittings includes both self-propelled models and models for swinging up to 45° slopes. You can choose up to 3 different types of inter-changeable cutting decks and they can be quickly and safely changed using a simple power take-off (PTO). All with 4 stroke Honda petrol engines and mechanical drive.

### TRT FORESTRY CUTTING DECK



### MC MULCHING CUTTING DECK

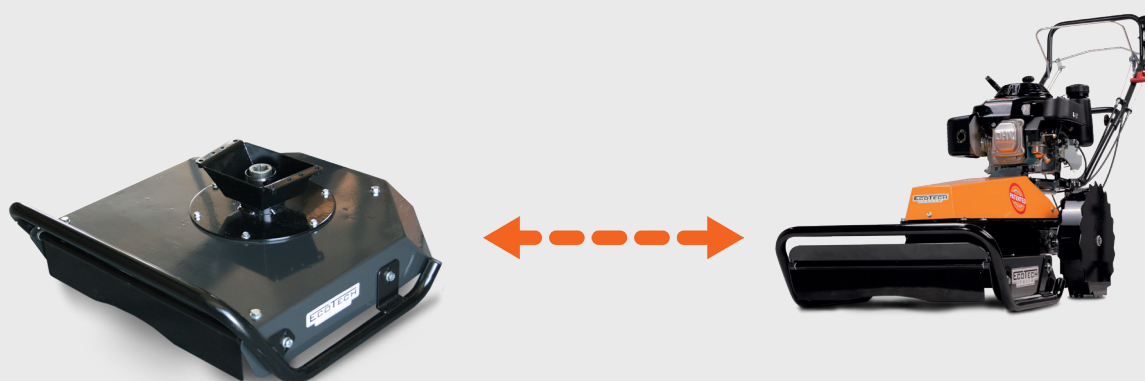

### DCS STRING TRIMMER CUTTING DECK

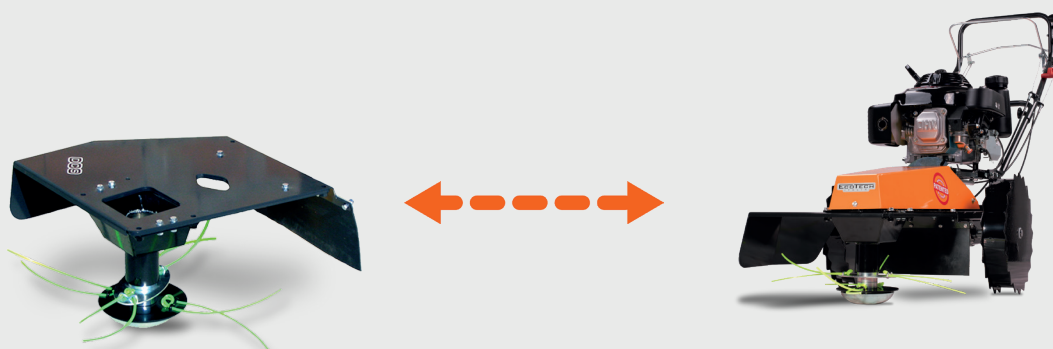



## OPTIONAL ACCESSORIES

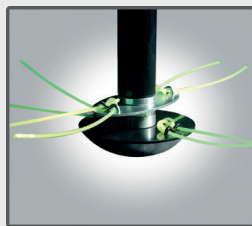

Double cutting head



Extra strong string # 20  
/ 50 items



#4/8 Hardened steel  
blades



13" pneumatic wheels



13" steel crawler wheels

TECHNICAL DATA	ML 60 SWING
Engine	Honda GXV 160 Professional
Displacement	163 cc
Transmission	Mechanical
Gears	Variable speed
Speed	From 1 to 2,3 Km/h
Brake	Automatic
Swinging	0° - 15° - 30° - 45° dx-sx (left and right)
Wheels	13" steel crawler
Track	520 - 780 mm
Dry weight (without cutting deck)	40 Kg
Guaranteed sound pressure Lwa	98 dB

### CUTTING DECK TECHNICAL DATA

Type	TRT	MC	DCS
Cutting heigh	30-45-60 mm	30-45-60 mm	30-45-60 mm
Cutting width	500 mm	500 mm	MAX 600 mm
Weight	16 Kg	15 Kg	12 Kg
Length machine+cutting deck	960 mm	980 mm	780 mm

# HYDROSTATIC SERIES

New professional series with hydrostatic transmission and two independent hydrostatic motors with SYNCRODRIVE™ technology that keeps the two motors perfectly in phase. Easy to use controls in forward and reverse directions. All with professional 4-stroke Honda petrol engine with recoil starter, adjustable cutting height from 20 to 80 mm and cutting width from 650 to 800 mm. Equipped with completely foldable handlebar for transportation.

## HSR 110 (COD. 771) PROFESSIONAL FLAIL MOWER



### DETAILS



Cutting rotor with 38 blades



Cutting height adjuster



Adjustable handlebar for transportation

### OPTIONAL ACCESSORIES



Cutter deck skids

16" helical steel crawler wheels



# HSR 135 SWING (COD. 786)

SWINGING PROFESSIONAL FLAIL MOWER FOR SLOPES

## DETAILS



80 cm cutting rotor with 46 blades

Full closure handlebar for transportation



## OPTIONAL ACCESSORIES



16" pneumatic wheels





<b>TECHNICAL DATA</b>	<b>HSR 110</b>
<b>Engine</b>	Honda GXV 390 Professional
<b>Displacement</b>	390 cc
<b>Transmission</b>	Hydrostatic
<b>Reverse</b>	1.3 Km/h
<b>Speed</b>	0 - 5 Km/h
<b>Brake</b>	Automatic
<b>Swinging</b>	0° - 15° - 30° - 45° dx-sx (left and right)
<b>Wheels</b>	16" helical steel crawler
<b>Track</b>	750 - 950 mm
<b>Cutting height</b>	20 - 40 - 60 - 80 mm
<b>Cutting width</b>	680 mm
<b>Dry weight</b>	150Kg
<b>Guaranteed sound pressure Lwa</b>	98 dB

<b>TECHNICAL DATA</b>	<b>HSR 135 SWING</b>
<b>Engine</b>	Honda GXV 390 Professional
<b>Displacement</b>	390 cc
<b>Transmission</b>	Hydrostatic
<b>Reverse</b>	1.3 Km/h
<b>Speed</b>	0 - 5 Km/h
<b>Brake</b>	Automatic
<b>Swinging</b>	0° - 15° - 30° - 45° dx-sx (left and right)
<b>Wheels</b>	16" helical steel crawler
<b>Track</b>	750 - 950 mm
<b>Cutting height</b>	20 - 40 - 60 - 80 mm
<b>Cutting width</b>	800 mm
<b>Dry weight</b>	160 Kg
<b>Guaranteed sound pressure Lwa</b>	98 dB



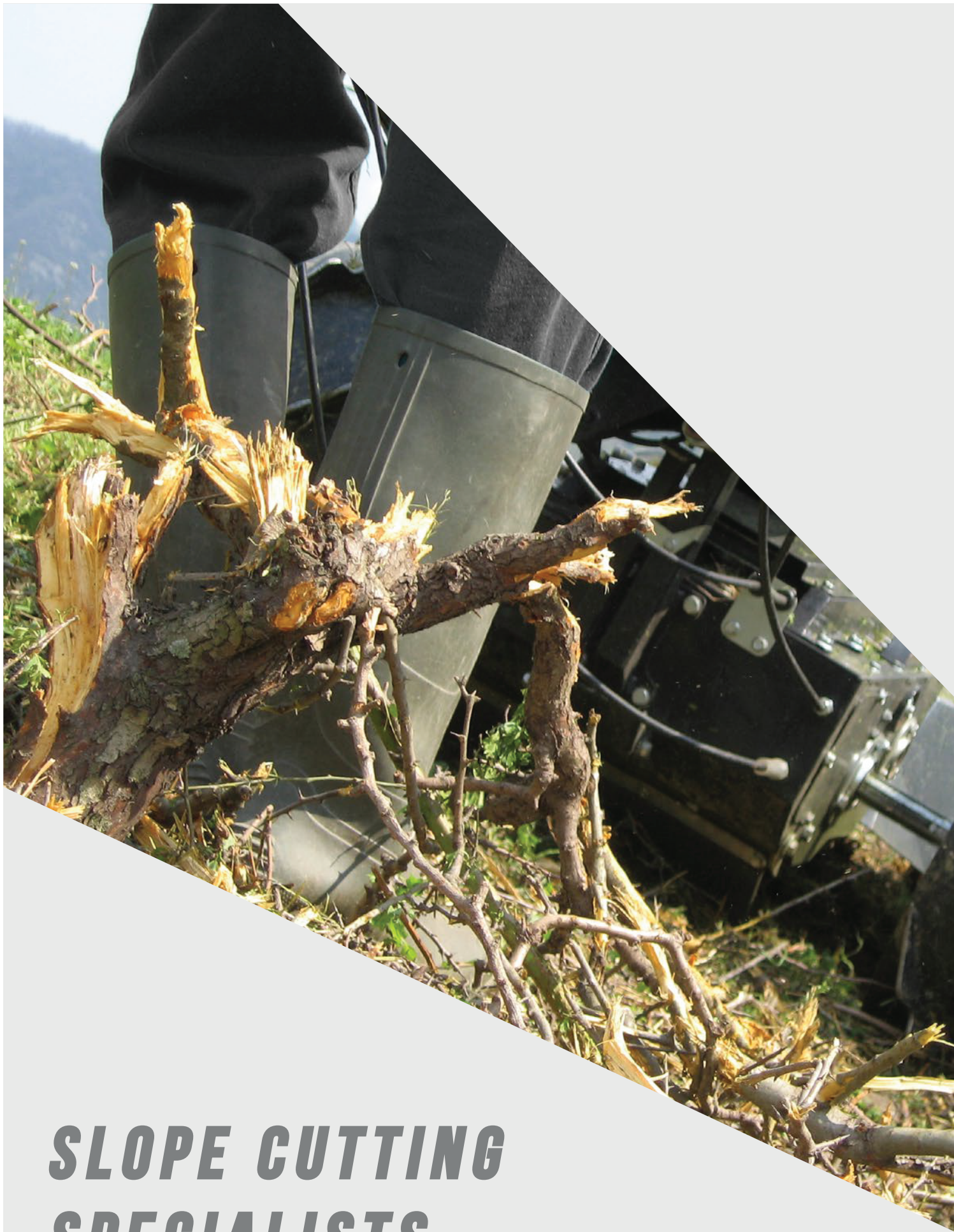

# ***SLOPE CUTTING SPECIALISTS***







Via Dovizi 18  
47122 Forlì - FC - Italy  
Tel. 0543-774314  
email: [info@ecotechitalia.com](mailto:info@ecotechitalia.com)



Regent House  
Regent Street  
Whitewalls Industrial Estate  
Colne  
BB8 8LJ

Tel. +44(0)1282 856819  
Email. [sales@psdgroundscare.com](mailto:sales@psdgroundscare.com)  
[www.psdgroundscare.com](http://www.psdgroundscare.com)

2022-2023 All rights reserved

[www.ecotechitalia.com](http://www.ecotechitalia.com)